

# FH-CHJ Skid Sickle Bar Mower



# FHM

**FARMER-HELPER  
MACHINERY COMPANY**



## OPERATION & PARTS MANUAL

*Please read these instructions before using. Always grease all fittings and be sure to always check and fill with oil before operating! Retain this manual for future use.*

**BETSTCO** 

RUGGED LABOR SAVING EQUIPMENT SINCE 1995

[www.Betstco.com](http://www.Betstco.com)

541-895-3083 M-F 7am-4pm PST

83371 Melton Rd, Creswell OR 97426



INTRODUCTION  
SAFETY NOTES  
GENERAL INFORMATION  
SPECIFICATIONS  
PARTS DRAWINGS AND LIST

# 1 INTRODUCTION

Congratulations on your choice of a Farmer-Helper Skid Steer Sickle Bar Mower to compliment your operation. This equipment has been designed and manufactured to meet the needs of a discerning timber and landscaping industry.

Safe, efficient and trouble free operation of your Farmer-Helper Sickle Bar Mower requires that you and anyone else who will be using or maintaing the Sickle bar, read and understand the saftey, Operation,Maintenance Trouble Shooting information contained within the Operations Manual.



CHJ150

This manual covers the Farmer-Helper Skid Steer Sickle Bar Mower. Use the Table of Contents as a guide to locate required information

Keep this manual handy for frequent reference and to pass on to new operators or owners.

**OPERATION ORIENTATION** - The directions left, right, front and rear, as mentioned throughout this manual are determined when sitting in the tractors driver seat and facing in the direction of travel.

# SAFETY ALERT SYMBOL

THIS SAFETY ALERT SYMBOL MEANS  
**ATTENTION! BECOME ALERT!**  
**YOUR SAFETY IS INVOLVED!**



The safety alert symbol identifies important safety messages on the Farmer-Helper Skid Steer Sickle Bar Mower and in the manual. When you see this symbol, be alert to the possibility of personal injury or DEATH. Follow the instructions in the safety message.

## Why is SAFETY important?

### 3 Big Reasons

#### Signal words:

Note the use of the signal words DANGER, WARNING and CAUTION with safety messages. The appropriate signal word for each message has been selected using the following guidelines:

### Accidents Disable and Kill Accidents Cost Accidents Can Be Avoided

- DANGER -** Indicates an imminently hazardous situation that, if not avoided, will result in serious injuries or death. This signal word is to be limited to the most extreme situations typically for machine components which, for functional purposes, cannot be guarded.
- WARNING -** Indicates a potentially hazardous situation that, if not avoided, could result in serious injuries or death, and includes hazards that are exposed when guards are removed. It may also be used to alert against unsafe practices.
- CAUTION -** Indicates a potentially hazardous situation that, if not avoided, may result in minor or moderate injury. It may also be used to alert against unsafe practices.

## 2 SAFETY

YOU are responsible for the SAFE operation and maintenance of your Farmer-Helper CHJ 150. You must ensure that you and anyone else who is going to use, maintain or work around. This manual will take you step-by-step through your working day and alerts you to all good safety practices that should be used while using your Sickle Bar Mower.

Remember, YOU are the key to safety. Good safety practices not only protect you but also the people around you.

Make these practices a working part of your safety program. Be certain that EVERYONE using this equipment is familiar with the recommended using and maintenance procedures and follows all the safety precautions. Most accidents can be prevented. Do not risk injury or death by ignoring good safety practices

Skid Steer Sickle Mower Bar owners must give operating instructions to operators or employees before allowing them to operate the machine, and at least annually thereafter.

The most important safety device on this equipment is a SAFE operator. It is the operator's responsibility to read and understand ALL safety and operating instructions in the manual and to follow these. Most accidents can be avoided.

A person who has not read and understood all using and safety instructions is not qualified to use the machine. An untrained operator exposes himself and bystanders to possible serious injury or death.

Do not modify the equipment in any way. Unauthorized modification may impair the function and/or safety and could affect the life of the equipment.

THINK SAFETY! WORK SAFELY!

## 2.1 GENERAL SAFETY

1. Read and understand the Operators manual and all safety signs before using, maintaining, adjusting or cleaning the Skid Steer Sickle Bar Mower. 
2. Have a first-aid kit available for use should need arise and know how to use it 
3. Have a fire extinguisher available for use should need arise and know how to use it. 
4. Do not allow riders.
5. Wear appropriate protective gear. This list includes but is not limited to:
  - A hard hat
  - Protective shoes/Non Slip
  - Protective eyewear
  - Wet weather gear
  - Hearing protection
  - Respirator or filter mask
6. Install and secure all guards before starting.
7. Wear suitable ear protection for prolonged exposure to excessive noise. 
8. Turn machine off, stop and disable engine, remove ignition key and place in your pocket, set park brake and wait for all moving parts to stop before servicing, adjusting, repairing or unplugging
9. Clear the area of people, especially small children, before using the unit.
10. Review safety related items annually with all personnel who will operating or maintaining the Skid Steer Sickle Bar Mower

## 2.2 EQUIPMENT SAFETY GUIDELINES

Safe of the operator and bystanders is one of the main concerns in designing and developing equipment. However, every year many accidents occur which could have been avoided by a few seconds of thought and a more careful approach to handling equipment. You, the operator, can avoid many accidents by observing the following precautions in this section. To avoid personal injury or death, study the following precautions and insist those working with you, or for you to follow them.

In order to provide a better view, certain photographs or illustrations in this manual may show an assembly with a safety shield removed. However, equipment should never be used in this condition. Keep all shields in place. If shield removal becomes necessary for repairs, replace

Replace any safety sign or instruction sign that is not readable or is missing. Location of such safety signs is indicated in this manual.

Never use alcohol or drugs which can hinder alertness or coordination while using this equipment. Consult your doctor about using medication while operating

**UNDER NO CIRCUMSTANCES SHOULD YOUNG CHILDREN BE ALLOWED TO WORK WITH THIS EQUIPMENT. DO NOT ALLOW PERSONS TO USE OR ASSEMBLE THIS UNIT UNTIL THE HAVE READ THIS MANUAL AND HAVE DEVELOPED A THOROUGH UNDERSTANDING OF THE SAFETY PRECAUTIONS AND HOW IT WORKS.**

This equipment is dangerous to children and persons unfamiliar with its operation. The operator should be responsible, properly trained and physically able person with familiar with machinery and trained in this equipments operations. If the elderly are assisting with work, their physical limitations need to recognized and accommodated.

Never exceed the limits of a piece of machinery. If its ability to do a job, or to do so safely, is in question -DON'T TRY IT

Do not modify the equipment in any way. unauthorized modification may result in serious injury or death and may impair the function and life of the equipment.

In addition to the desing and configuration of this implement, including Saftey Signs and Saftey Equipment, hazard control and accident prevention and dependent upon the awareness, concern, prudence, and proper training of personal involved in the operation, transport, maintenance, and storage of the machine. Refer aslo to Safety Messages and operation instruction in each of the appropriate sections of the tractor and machine materials. pay close attentions to the Saftey Signs affixed to the tractor and the machine .

## 2.3 SAFETY TRAINING

1. Safety is a primary concern in the design and manufacture of our products. Unfortunately, our efforts to provide safe equipment can be wiped out by a single careless act of an operator or bystander.
2. In addition to the design and configuration of equipment, hazard control and accident prevention are dependent upon the awareness, concern, prudence and proper training of personnel involved in the operation, transport, maintenance and storage of this equipment.
3. It has been said, "The best safety feature is an informed, careful operator." We ask you to be that kind of an operator. It is the operator's responsibility to read and understand ALL Safety and Using instructions in the manual and to follow these. Accidents can be avoided.A circular icon with a blue background and a white border. Inside the circle, a white silhouette of a person is shown sitting and reading a document or manual.
4. Working with unfamiliar equipment can lead to careless injuries. Read this manual before assembly or using, to acquaint yourself with the machine. If this machine is used by any person other than yourself, or is loaned or rented, it is the machine owner's responsibility to make certain that the operator, prior to using:
  - a. Reads and understands the operator's manuals.
  - b. Is instructed in safe and proper use.
5. Know your controls and how to stop tractor and machine quickly in an emergency. Read this manual and the one provided with tractor.
6. Train all new personnel and review instructions frequently with existing workers. Be certain only a properly trained and physically able person will use the machinery. A person who has not read and understood all using and safety instructions is not qualified to use the machine. An untrained operator exposes himself and bystanders to possible serious injury or death. If the elderly are assisting with the work, their physical limitations need to be recognized and accommodated.

## 2.4 SAFETY SIGNS

1. Keep safety signs clean and legible at all times.
2. Replace safety signs that are missing or have become illegible.
3. Replaced parts that displayed a safety sign should also display the current sign.
4. Safety signs displayed in Section 3 each have a part number in the lower right hand corner. Use this part number when ordering replacement parts.
5. Safety signs are available from your authorized Distributor or Dealer Parts Department or the factory.

### How to Install Safety Signs:

- Be sure that the installation area is clean and dry.
- Be sure temperature is above 50°F (10°C).
- Determine exact position before you remove the backing paper.
- Remove the smallest portion of the split backing paper.
- Align the sign over the specified area and carefully press the small portion with the exposed sticky backing in place.
- Slowly peel back the remaining paper and carefully smooth the remaining portion of the sign in place.
- Small air pockets can be pierced with a pin and smoothed out using the piece of sign backing paper.

## 2.5 PREPARATION

1. Never use the machine until you have read and completely understand this manual, the tractor Operator's Manual and each of the Safety Messages found on the safety signs on the tractor and machine.
2. Personal protection equipment including hard hat, safety glasses, safety shoes, and gloves are recommended during assembly, installation, operation, adjustment, maintaining, repairing, removal, cleaning, or moving the unit. Do not allow long hair, loose fitting clothing or jewellery to be around equipment.



3. **PROLONGED EXPOSURE TO LOUD NOISE MAY CAUSE PERMANENT HEARING LOSS!**  
Power equipment with or without equipment attached can often be noisy enough to cause permanent, partial hearing loss. We recommend that you wear hearing protection on a full-time basis if the noise in the Operator's position exceeds 80db. Noise over 85db on a long-term basis can cause severe hearing loss. Noise over 90db adjacent to the Operator over a long-term basis may cause permanent, total hearing loss. NOTE: Hearing loss from loud noise (from tractors, chain saws, radios, and other such sources close to the ear) is cumulative over a lifetime without hope of natural recovery.
4. Clear working area of stones, branches or hidden obstacles that might be hooked or snagged, causing injury or damage.
5. Use only in daylight or good artificial light.
6. Be sure machine is properly mounted, adjusted and in good operating condition.
7. Ensure that all safety shielding and safety signs are properly installed and in good condition.



## 2.5 MAINTENANCE SAFETY

1. Good maintenance is your responsibility. Poor maintenance is an invitation to trouble.
2. Follow good shop practices.
  - Keep service area clean and dry.
  - Be sure electrical outlets and tools are properly grounded.
  - Use adequate light for the job at hand.
3. Make sure there is plenty of ventilation. Never operate the engine of the towing vehicle in a closed building. The exhaust fumes may cause asphyxiation.
4. Before working on this machine, shut off the engine, set the brake, and turn fuel valve off.
5. Never work under equipment unless it is blocked securely.
6. Always use personal protection devices such as eye, hand and hearing protectors, when performing any service or maintenance work. Use heavy or leather gloves when handling blades.
7. Where replacement parts are necessary for periodic maintenance and servicing, genuine factory replacement parts must be used to restore your equipment to original specifications. The manufacturer will not be responsible for injuries or damages caused by use of unapproved parts and/or accessories.
8. A fire extinguisher and first aid kit should be kept readily accessible while performing maintenance on this equipment.
9. Periodically tighten all bolts, nuts and screws and check that all electrical and fuel connections are properly secured to ensure unit is in a safe condition.
10. When completing a maintenance or service function, make sure all safety shields and devices are installed before placing unit in service.



## 2.7 OPERATING SAFETY

1. Please remember it is important that you read and heed the safety signs on the Skid Steer Loader Wood Chipper. Clean or replace all safety signs if they cannot be clearly read and understood. They are there for your safety, as well as the safety of others. The safe use of this machine is strictly up to you, the operator.
2. All things with moving parts are potentially hazardous. There is no substitute for a cautious, safe-minded operator who recognizes potential hazards and follows reasonable safety practices. The manufacturer has designed this Skid Steer Loader Wood Chipper to be used with all its safety equipment properly attached, to minimize the chance of accidents. Study this manual to make sure you have all safety equipment attached.
3. Close and secure rotor cover before operating.
4. Close and secure all guards, deflectors and shields before starting and operating.
5. Read and understand operator's manual before starting. Review safety instructions annually.
6. Personal protection equipment including hearing protection, hard hat, safety glasses, safety shoes, and gloves are recommended during assembly, installation, operation, adjustment, maintaining, repairing, removal, or moving. Do not allow long hair, loose-fitting clothing, or jewellery to be around moving parts.
7. Keep hydraulic lines and fittings tight, in good condition and free of leaks.
8. Never place any part of your body where it would be in danger if movement should occur during assembly, installation, operation, maintenance, repairing, unplugging or moving.
9. Turn machine off, stop and disable engine, remove ignition key and place in your pocket, set park brake and wait for all moving parts to stop before servicing, adjusting, repairing or unplugging.
10. Do not run machine inside a closed building to prevent asphyxiation from engine exhaust.
11. Use care when feeding material into chipper. Do not send metal, bottles, cans, rocks, glass or other foreign material into wood chipper. If foreign material enters chipper, stop machine, turn engine off and place ignition key in your pocket and wait for all moving parts to stop before removing material and/or unplugging. Inspect machine for damaged or loose parts before resuming work.
12. Never use alcoholic beverages or drugs which can hinder alertness or coordination while operating this equipment. Consult your doctor about operating this machine while taking prescription medications.
13. Do not allow riders on this machine at any time. There is no safe place for any riders.
14. Never allow children or unauthorized people to operate or be around this machine.
15. Do not reach into rotor or feed hopper openings when the engine is running. Install and secure access covers before starting engine.
16. Keep the working area clean and free of debris to prevent tripping. Operate only on level ground.
17. Do not point discharge at people, animals or buildings. Rotor can expel wood chips fast enough to cause injury.
18. Do not move or transport chipper when the rotor is turning.
19. Do not exceed a safe travel speed when transporting.

## 2.8 HYDRAULIC SAFETY

1. Make sure that all the components in the hydraulic system are kept in good condition and are clean.
2. Before applying pressure to the system, make sure all components are tight, and that lines, hoses and couplings are not damaged.
3. Do not attempt any makeshift repairs to the hydraulic lines, fittings or hoses by using tapes, clamps or cements. The hydraulic system operates under extremely high pressure. Such repairs will fail suddenly and create a hazardous and unsafe condition.
4. Wear proper hand and eye protection when searching for a high pressure hydraulic leak. Use a piece of wood or cardboard as a backstop instead of hands to isolate and identify a leak.
5. If injured by a concentrated high-pressure stream of hydraulic fluid, seek medical attention immediately. Serious infection or toxic reaction can develop from hydraulic fluid piercing the skin surface.
6. Relieve pressure on hydraulic system before maintaining or working on system.



## 2.9 STORAGE SAFETY

1. Store the unit in an area away from human activity.
2. Do not children to play on or around the stored machine.
3. Store the unit in a dry, level area. Support the frame with planks if required.

## 2.10 TRANSPORT SAFETY

1. Comply with state and local laws governing safety and transporting of machinery on public roads.
2. Check that all the lights, reflectors and other lighting requirements are installed and in good working condition.
3. Do not exceed a safe travel speed. Slow down for rough terrain and cornering.
4. Fold up and secure feed hopper before moving or transporting.
5. Be sure the machine is hitched positively to the tractor and a retainer is used through the mounting pins.
6. Do not drink and drive.
7. Be a safe and courteous driver. Always yield to oncoming traffic in all situations, including narrow bridges, intersections, etc. Watch for traffic when operating near or crossing roadways.
8. Never allow riders on the machine.

Good safety requires that you familiarize yourself with the various safety signs, the type of warning and the area, or particular function related to that area, that requires your SAFETY AWARENESS.

- Think SAFETY! Work SAFELY!



Specifications in Inch			
Model	CHJ120	CHJ150	CHJ180
Without Trimmer Head Weight	242 lbs		
Trimmer Head Only Weight	93 lbs	115 lbs	134 lbs
Total Weight	335 lbs	357 lbs	376 lbs
Required Hydraulic Pressure	2250 to 3500 PSI	2250 to 3500 PSI	2250 to 3500 PSI
Required Hydraulic Flow	8 GPM to 11 GPM	8 GPM to 11 GPM	8 GPM to 11 GPM
Brush Cutting Diameter	3/4	3/4	3/4
Cutting Bar	47"	59"	71"

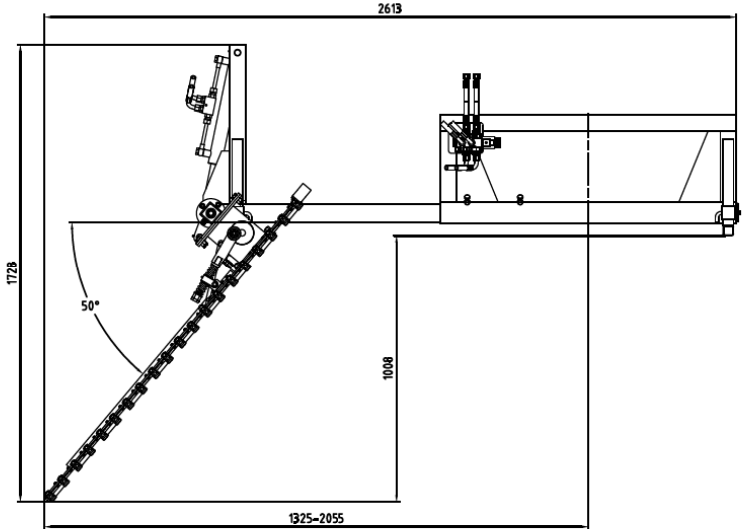
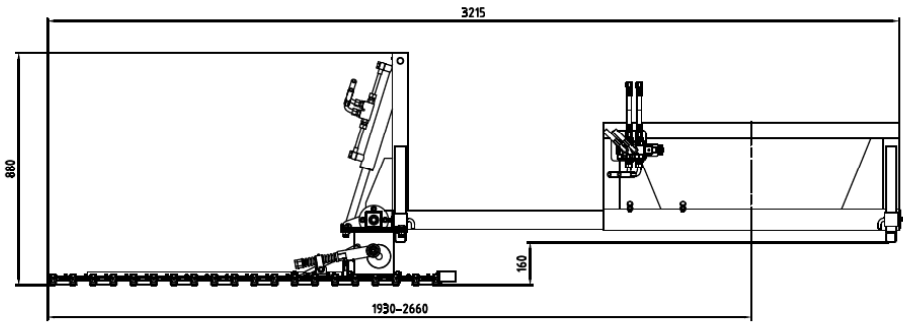
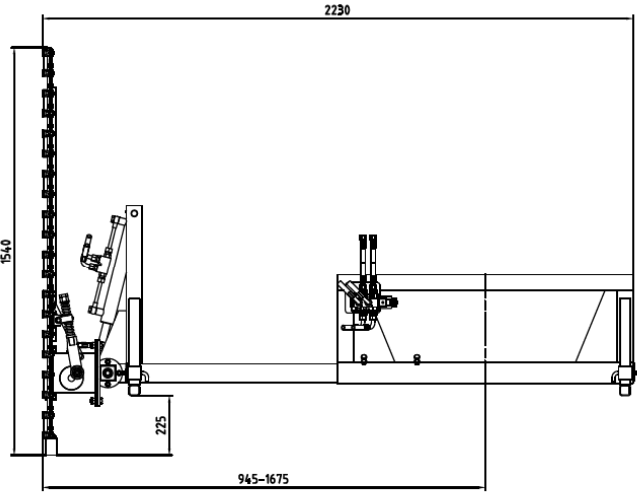

# Schematic -CHJ、CHG and CHS

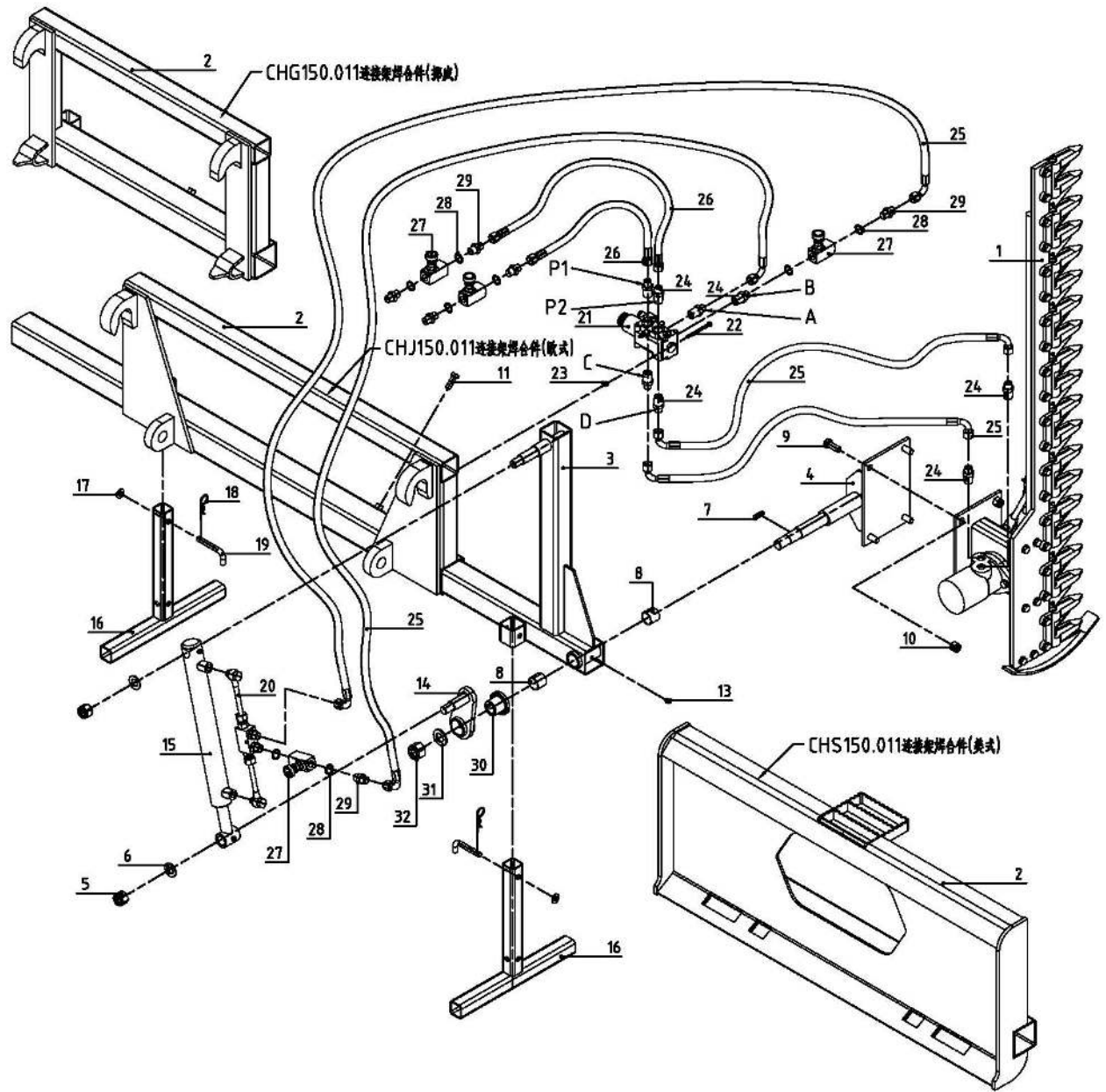

### **Parts List –CHJ、CHG and CHS**

NO.	PART NO.	Name & Specifications	名称	QTY
1	CH150.001	Hedge trimmer	剪草器总成	1
2	CHJ150.011	Hanging Weldment(EURO Hitch)	欧式连接架焊合件	1
	CHG150.011	Hanging Weldment(SMS Hitch)	挪威连接架焊合件	
	CHS150.011	Hanging Weldment(Skidder Hitch)	美式连接架焊合件	
3	CHJ150.012	Beam Weldment	横梁焊合件	1
4	CHJ150.013	Rotation Seat Weldment	旋转座焊合件	1
5	GB/T889.1-2000	Lock Nut M20	锁紧螺母M20	2
6	GB/T97.1-1987	Plain Washer	平垫圈20	2
7	GB / T1096-1979	Key A 8x22	普通平键A型8×32	1
8	CHJ150.102	Bearing 30*34*30	无油轴承 $\phi 30 * \phi 34 * 30$	2
9	GB/T5783-2000	Bolt M14*35	螺栓M14*35	4
10	GB/T889.1-2000	Lock Nut M14	锁紧螺母M14	4
11	GB/T5783-2000	Bolt M12*35	螺栓M12*35	2
13	JB / T7940. 1-1995	Oil Cup M8	油杯M8	1
14	CHJ150.014	Swing Arm Weldment	摆臂焊合件	1
15	CHJ150.015	Cylinder	油缸	1
16	CHJ150.016	Support Leg	撑腿焊合件	2
17	GB/T97.1-1987	Plain Washer	平垫圈12	2
18		R Pin 3.2	R销3.2	2
19	1G135.00.107	Plug Pin	插销	2
20		Safety Valve	安全阀总成	1

21	DV26.001	Solenoid Valve	电磁阀总成	1
22	GB/T5783-2000	Bolt M8x80	螺栓M8*80	2
23	GB/T889.1-2000	Lock Nut M8	锁紧螺母M8	2
24	CP5.60.104	Adapter R1/2-M18*1.5	接头R1/2-M18*1.5	8
25	CHJ150.017	Oil Hoses	油管	4
26	CHJ150.018	In-out oil hose	进出油管	2
27	LA-H10L	One- way throttle valve	单向节流阀40L	4
28		Washer 18	组合垫圈18	8
29		Adapter 18-18	接头18-18（两端内锥）	6
30	CHJ150.019	Gear bush weldment	盘齿套焊合件	1
31	GB / T97. 1-2002	Plain Washer 24	平垫圈24	1
32	GB/T889.1-2000	Lock nut M24	锁紧螺母M24	1



**FHM**  
FARMER-HELPER  
MACHINERY COMPANY

# Parts Request Form

E-mail [cservice@betstco.com](mailto:cservice@betstco.com)

Name: \_\_\_\_\_

Address: \_\_\_\_\_

City State Zip: \_\_\_\_\_

Phone: \_\_\_\_\_

E-mail: \_\_\_\_\_

Model Number: _____
Serial Number: _____
Purchased From: _____
Purchase Date: _____

Item No.	Description	Qty	Price	Amount

Comments:

## **FARMER-HELPER Limited Warranty**

Unless otherwise stated on purchase invoice, Betstco warrants to original Purchaser that Farmer-Helper products are free from major defects in material under normal use and service for a period of 90 Days from the date the product is purchased or shipped, whichever is later. Commercial use 90 days. Use at address that is not yours, is considered commercial use. Consumable, Expendable, Wear Items (Rubber plastic parts, hydraulic hoses, belts, tires, cables, blades, tines, wedges, teeth, tiups, chains, pins, brushes, filters, etc) and cracked hydraulic pumps, bent or broken cylinder rods are not covered under this warranty. Warranty does not cover items that have been modified, damaged by abuse or usage not in accordance with design or maintenance.

Betstco obligation under this warranty is to repair or replace defective upon approval by; Betstco, 83371 Melton Rd. N, Creswell OR 97426 that Warranty Claim is valid. Product shall be returned upon request of Betstco. Transportation charges to be prepaid by user.

**Gasoline or diesel engines used to powered Farmer-Helper products are covered by the warranty of the appropriate engine manufacturean Purchaser must look to the engine manufacture for all issues relating to engine operation.**

### ***Betstco assumes no responsibility for outside labor.***

***PERMISSABLE BY APPLICABLE LAW, BETSTCO HEREBY DISCLAIMS ALL WARRANTIES OF ANY KIND, EITHER EXPRESS OR IMPLIED, INCLUDING, ANY IMPLIED WARRANTIES WITH RESPECT TO THE PRODUCT PURCHASED, WITHOUT LIMITING THE GENERALITY OF THE FOREGOING, BETSTCO HEREBY EXPRESSLY DISCLAIMS ALL LIABILITY FOR PRODUCT DEFECT OR FAILURE, CLAIMS THAT ARE DUE TO NORMAL WEAR, PRODUCT MISUSE, ABUSE, PRODUCT MODIFICATION, IMPROPER PRODUCT SELECTION, NON-COMPLIANCE WITH ANY CODES, OR MISAPPROPRIATION. BETSTCO MAKES NO WARRANTIES TO THOSE DEFINED AS "CONSUMERS" IN THE MAGNUSON-MOSS WARRANTY FEDERAL TRADE COMMISION IMPROVEMENTS ACT. THE FOREGOING EXCLUSION OF IMPLIED WARRANTIES DO NOT APPLY TO THE EXTENT PROHIBITED BY LAW. PLEASE REFER TO YOUR LOCAL LAWS FOR ANY SUCH PROHIBITIONS.***

***THERE SHALL BE NO LIABILITY FOR PRODUCT LIABILITY OR LIABILITY ON THE PART OF BETSTCO FOR ANY GENERAL SPECIAL OR CONSEQUENTIAL DAMAGES ARISING OUT OF THE SALE OR USE OF ANY PRODUCTS SOLD BY BETSTCO OR AN AGENT THEREOF, BETSTCO MAKES NO WARRANTIES, EXPRESS OR IMPLIED, (INCLUDING, BUT NOT LIMITED TO, ANY WARRANTY OF MERCHANTABILITY OR FITNESS OF THE PRODUCTS FOR ANY PURPOSE) WITH RESPECT TO THE PRODUCTS COVERED BY THIS AGREEMENT EXCEPT AS IN THIS PARAGRAPH OTHERWISE EXPRESSLY PROVIDED.***

***THIS IS THE SOLE AND ONLY WARRANTY OF VALUE-LEADER PRODUCTS, NO OTHER WARRANTY IS APPLICABLE, EITHE EXPRESSED OR IMPLIED, IN FACT BY LAW.***

**WARRANTY VOID IF REGISTRATION IS NOT RECEIVED OR RECORDED ONLINE WITHIN 30 DAYS OF PURCHASE DATE OR SHIP DATE, WHICHEVER IS LATER.**

ITEM: \_\_\_\_\_ MODEL# \_\_\_\_\_ PURCHASE DATE: \_\_\_\_/\_\_\_\_/\_\_\_\_

PURCHASED FROM: \_\_\_\_\_ GIFT INV# ORDER# \_\_\_\_\_

OWNER NAME: \_\_\_\_\_ SERIAL # \_\_\_\_\_

OWNER ADDRESS: \_\_\_\_\_

CITY: \_\_\_\_\_ COUNTY: \_\_\_\_\_ ST: \_\_\_\_\_ ZIP: \_\_\_\_\_

PHONE: \_\_\_\_\_ EMAIL: \_\_\_\_\_

**ACCEPTANCE OF RESPONSIBILITY:**

I (PURCHASER) HAVE READ OPERATORS MANUAL AND LIMITED WARRANTY OR SOMEONE HAS READ/AND EXPLAINED ALL INSTRUCTIONS TO ME. I UNDERSTAND THIS WARRANTY DOES NOT COVER ANY LABOR AND THAT ALL DISPUTES WILL BE SETTLED BY BINDING ARBITRATION. BINDING ARBITRATION IS CONDUCTED BY THE BETTER BUSINESS BUREAU (BBB) LOCATED AT 4004 SW KRUSE WAY PLACE ST 375 LAKE OSWEGO OR 97035 OR THE CURRENT BBB LOCATION CLOSEST TO BETSTCO. I ACKNOWLEDGE MY LIMITED WARRANTY IS VOID IF ANY ATTEMPT TO REPAIR OR REPLACE DEFECTIVE PARTS HAS BEEN MADE BY UNAUTHORIZED PERSONNEL. I ACKNOWLEDGE RECEIPT OF MY OPERATORS MANUAL AND HAVE READ THE SAFE OPERATION SECTION. I ACKNOWLEDGE UNDERSTANDING MAINTENANCE AND SAFE OPERATION REQUIREMENTS, ITEM SPECIFICATIONS, OPERATION, CONTROLS AND STORAGE REQUIREMENTS. **I UNDERSTAND THAT IS ALONE AM RESPONSIBLE FOR PROPER MAINTENANCE, CARE AND SAFE OPERATION OF THIS FARMER-HELPER ITEM**

**1 YEAR EXTENDED WARRANTY & REGISTRATION  
FARMER-HELPER IMPLEMENTS  
BRANDED PRODUCTS  
1 YEAR EXTENDED WARRANTY**

1 Year Extended Warranty amends to original Recorded Warranty Registration the time period of described coverage. Extended Warranty does not apply to consumable and Expendable Item as described in Product Warranty Registration.

This amendment does not affect any other part of recorded Warranty Registration or policy.

No one is authorized to alter, modify, or enlarge this Amendment to original recorded Warranty Registration

**EXTENDED REGISTRATION & PAYMENT MUST BE RECEIVED  
WITHIN 30 DAYS OF PURCHASE DATE**

*EXTENDED WARRANTY REGISTRATION*

PRODUCT & MODEL # \_\_\_\_\_

SERIAL # \_\_\_\_\_

OWNER NAME : \_\_\_\_\_

BETSTCO INVOICE # \_\_\_\_\_

**ACCEPTANCE OF RESPONSIBILITY:**

I (PURCHASER) HAVE READ AND UNDERSTAND THE EXTENDED WARRANTY OR SOMEONE HAS READ AND EXPLAINED ALL THE ABOVE TO ME. I UNDERSTAND THIS EXTENDED WARRANTY DOES NOT COVER ANY LABOR. I HAVE FILED MY ORIGINAL WARRANTY REGISTRATION AND FULLY UNDERSTAND MY REQUIREMENTS. ***I UNDERSTAND THAT I ALONE AM RESPONSIBLE FOR PROPER MAINTENANCE, CARE AND SAFE OPERATION OF THIS TRACTOR IMPLEMENT.***