

FH-BG130 BALE GRIPPER



FHM

**FARMER-HELPER
MACHINERY COMPANY**



OPERATION & PARTS MANUAL

Please read these instructions before using. Always grease all fittings and be sure to always check and fill with oil before operating! Retain this manual for future use.

BETSTCO 

RUGGED LABOR SAVING EQUIPMENT SINCE 1995

www.Betstco.com

541-895-3083 M-F 7am-4pm PST

83371 Melton Rd, Creswell OR 97426



C O N T E N T S

	<u>Page:</u>
1. <u>INTRODUCTION</u>	3
2. <u>SAFETY PRECAUTIONS</u>	3, 4
3. <u>TECHNICAL DETAILS AND OPERATION</u>	5, 6
3.1 <u>PICTURE WITH PART SPECIFICATION</u>	5
3.2 <u>ASSEMBLY AND OPERATING INSTRUCTIONS</u>	6
4. <u>MAINTENANCE</u>	6
5. <u>WARRANTY</u>	6

1. INTRODUCTION

With your purchase of the Farmer-Helper Wrapped Bale Grabber you have made the right choice for the handling of your wrapped (or unwrapped) round bales. Through its unique construction it requires minimal maintenance.

Before using your bale grabber read this manual carefully to familiarize yourself with this machine. Operating unfamiliar machines may lead to accidents.

This operator's manual has been written to assist you in obtaining the best possible results from your Farmer-Helper Wrapped Bale Grabber. Keep it in a safe place so you can always use it as a reference booklet. If any questions should remain, however, you can contact Betstco, who will gladly assist you.

The bale grabber is designed to fit your front end loader or skid steer and easily adaptable to your quick-attach brackets (plate). You can grab all sizes of round bales up to 5 feet in diameter from any position for transportation and stacking.

CAUTION: Never use the bale grabber to lift or transport people!!!

2. SAFETY PRECAUTIONS

- Follow all the rules of operation from the operator's manual of your tractor or skid steer.
- Use a tractor with a roll-over protective system (ROPS).
- When using the bale grabber on sloping or uneven terrain, always maintain proper stability. It is therefore advisable to use a wide wheel track setting on your tractor. Also avoid sudden maneuvers and change of direction.
- While moving, make sure you keep the load low and as close to the tractor or skid steer as possible, because a heavy load can easily tip your tractor or skid steer over.
- Have the rear of your tractor or skid steer properly counter balanced with weights to create optimal stability.
- Comply with federal and local laws governing highway safety and movement of farm machinery on public roads.
- Make sure you place the bales on a flat and solid surface so they do not start rolling or moving unexpectedly.
- When in use, never stand within operating range of the bale grabber and never under a raised load.

- Strictly operate the bale grabber from your tractor or skid steer driver's seat and make sure you have a good view on your job.
- Make sure the grabber's arms can move freely and do not jam any hydraulic hoses.
- Do not confuse your bale grabber's controls with other controls on your tractor or skid steer to avoid unintentional operation.
- When you are driving and not carrying a bale, make sure your grabber is completely open (cylinder closed) to avoid cylinder damage.
- Take care! The hydraulic circuit operates under pressure. Make sure that the hydraulic systems of both your bale grabber and tractor or skid steer are de-pressurized before connecting any hoses between the two.
- Clearly label or tag the hydraulic fittings of the tractor or skid steer and bale grabber to avoid incorrect connection, which may lead to invert functions such as raising and lowering.
- Make sure that your hydraulic hoses do not get jammed during operation and never operate the bale grabber with a hydraulic hose that has been pinched.
- Regularly check all hydraulic hoses and replace any worn or damaged ones immediately. When replacing hoses, use only replacements compliant to original technical specifications.
- Take all possible precautions to avoid accidents when searching for hydraulic leaks.
- Remember that liquids under pressure, and especially oil, can penetrate the skin and cause serious injury. Consult a doctor immediately to prevent infection in case of injury.
- Before dismounting from your tractor or skid steer, always check if the bale grabber is lowered to the ground, the tractor or skid steer is in neutral and the parking brake applied. And always place your bale grabber on a flat and solid surface for storage.

3. TECHNICAL DETAILS AND OPERATION

3.1 Picture with part specification



1. Grab Arm

3. Main Frame

2. Cylinder

3.2 ASSEMBLY AND OPERATING INSTRUCTIONS

Because the Bale Grabber is a loading/stacking device, make sure that it is assembled by a qualified mechanic.

You pick up a round bale as follows:

- You drive up to the bale with your frame straight up and the grabbers as far apart as possible;
- Make sure the center of the frame touches the bale and the grabbers are on each side;
- When positioned correctly, you can operate the cylinder so the grabber will close and pick up the bale.

If you have to transport a bale before loading or stacking, make sure to keep it as low to the ground as possible to ensure the best stability. Especially on rough or uneven terrain or slopes make sure to maintain stability by using counter balance weights or a wide wheel setting on your tractor or skid steer.

Bales should be placed on a flat and solid surface to prevent them from moving/rolling and any bystanders should keep a safe distance from the machine.

If your bale grabber is equipped with a red tie-rods cylinder it is rated at 2500 PSI max. And if it is equipped with a black tie-rods or welded cylinder it is rated at 3000 PSI max.

4. MAINTENANCE

Little maintenance is required for the Farmer-Helper Wrapped Bale Grabber, but the following must be strictly followed.

It is equipped with four grease nipples that should be greased regularly.

Make sure to check and tighten all nuts and bolts prior to each use. You must lube all moving parts prior to each use as well. Any worn parts have to be replaced immediately.

In case you have to replace a part, make sure that it is a genuine Farmer-Helper part which can be obtained through Betstco.

5. WARRANTY

Warranty is at the sole discretion of the manufacturer. Your Farmer-Helper Bale Grabber has a two year warranty from the date of purchase to the original owner. It is limited to material and/or construction failures that have to be examined by the factory. So, if within two years from the date of purchase, your bale grabber fails due to a defect in material or workmanship, you will have to return it prepaid to the factory for inspection.

The warranty does not apply to damage received during transport.

<---Actual included frame mount*

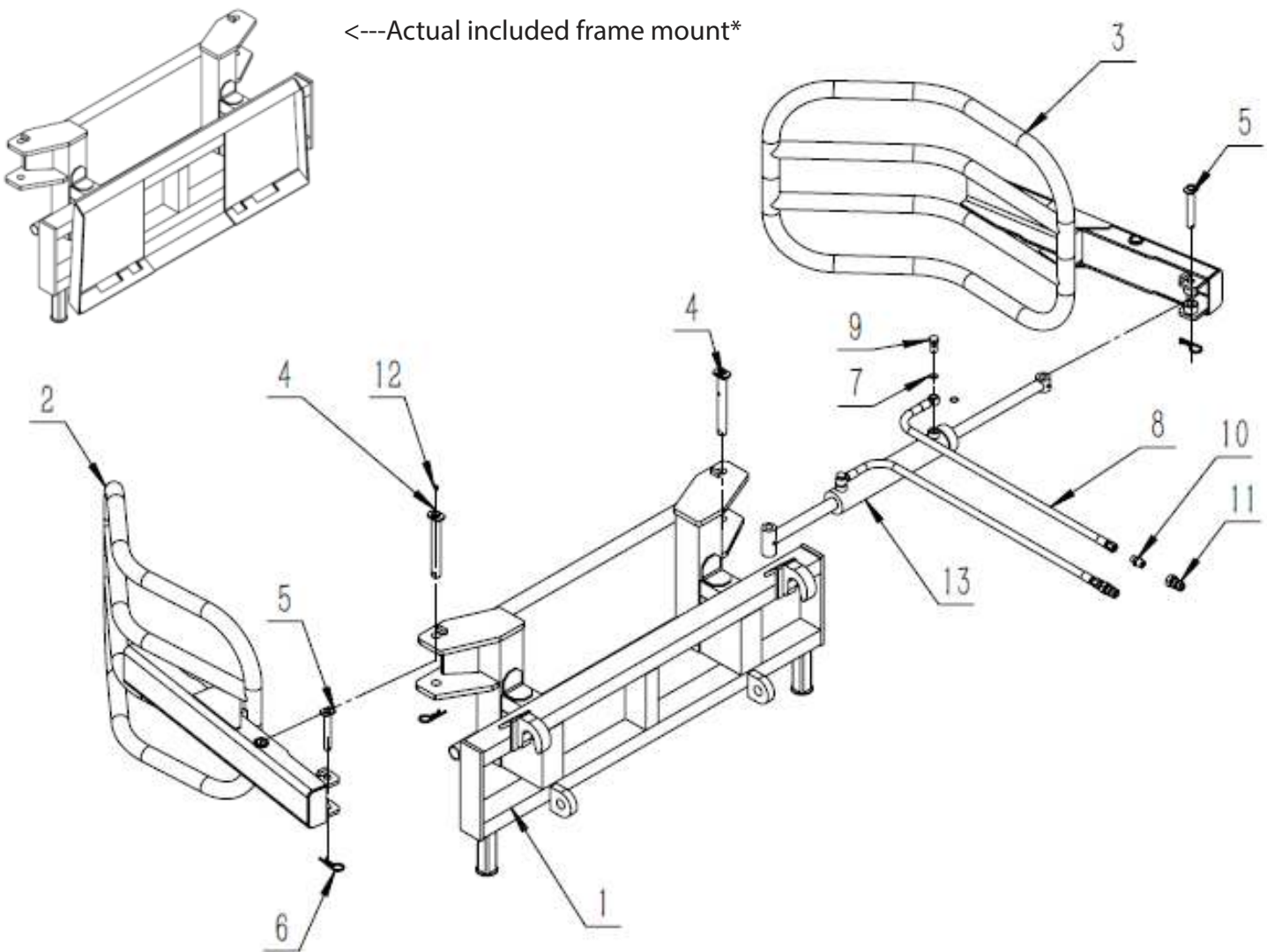

NO.	PART #	NAME & SPECIFACATION	QTY.	REMARK
1	bg130A.011	Main Frame	1	
2	BG130.012	Arm LH	1	
3	BG130.013	Arm RH	1	
4	BG130.014	Pin Arm	2	
5	BG130.015	Pin Cylinder	2	
6	RP-5	Cylinder Pin Retaining Clip	4	
7	JBZQ4454-18	Seal Gasket 18	4	
8	BG130.017	Bale Grabber Hose	4	
9	BG130.101	Bolt M18x1.5x36	2	
10	BX92RSA.30.101	Straight Fitting	2	
11	KJ-R1-2-M	Hydro Coupler 1/2"	2	
12	JB/T7940.1-8	Grease Fitting M8x1	2	
13	BG130.016	Cylinder, Assembly	1	



FHM
FARMER-HELPER
MACHINERY COMPANY

Parts Request Form

E-mail cservice@betstco.com

Name: _____

Address: _____

City State Zip: _____

Phone: _____

E-mail: _____

Model Number: _____
Serial Number: _____
Purchased From: _____
Purchase Date: _____

Item No.	Description	Qty	Price	Amount

Comments:

FARMER-HELPER Limited Warranty

Unless otherwise stated on purchase invoice, Betstco warrants to original Purchaser that Farmer-Helper products are free from major defects in material under normal use and service for a period of 90 Days from the date the product is purchased or shipped, whichever is later. Commercial use 90 days. Use at address that is not yours, is considered commercial use. Consumable, Expendable, Wear Items (Rubber plastic parts, hydraulic hoses, belts, tires, cables, blades, tines, wedges, teeth, tiups, chains, pins, brushes, filters, etc) and cracked hydraulic pumps, bent or broken cylinder rods are not covered under this warranty. Warranty does not cover items that have been modified, damaged by abuse or usage not in accordance with design or maintenance.

Betstco obligation under this warranty is to repair or replace defective upon approval by; Betstco, 83371 Melton Rd. N, Creswell OR 97426 that Warranty Claim is valid. Product shall be returned upon request of Betstco. Transportation charges to be prepaid by user.

Gasoline or diesel engines used to powered Farmer-Helper products are covered by the warranty of the appropriate engine manufacturean Purchaser must look to the engine manufacture for all issues relating to engine operation.

Betstco assumes no responsibility for outside labor.

PERMISSABLE BY APPLICABLE LAW, BETSTCO HEREBY DISCLAIMS ALL WARRANTIES OF ANY KIND, EITHER EXPRESS OR IMPLIED, INCLUDING, ANY IMPLIED WARRANTIES WITH RESPECT TO THE PRODUCT PURCHASED, WITHOUT LIMITING THE GENERALITY OF THE FOREGOING, BETSTCO HEREBY EXPRESSLY DISCLAIMS ALL LIABILITY FOR PRODUCT DEFECT OR FAILURE, CLAIMS THAT ARE DUE TO NORMAL WEAR, PRODUCT MISUSE, ABUSE, PRODUCT MODIFICATION, IMPROPER PRODUCT SELECTION, NON-COMPLIANCE WITH ANY CODES, OR MISAPPROPRIATION. BETSTCO MAKES NO WARRANTIES TO THOSE DEFINED AS "CONSUMERS" IN THE MAGNUSON-MOSS WARRANTY FEDERAL TRADE COMMISION IMPROVEMENTS ACT. THE FOREGOING EXCLUSION OF IMPLIED WARRANTIES DO NOT APPLY TO THE EXTENT PROHIBITED BY LAW. PLEASE REFER TO YOUR LOCAL LAWS FOR ANY SUCH PROHIBITIONS.

THERE SHALL BE NO LIABILITY FOR PRODUCT LIABILITY OR LIABILITY ON THE PART OF BETSTCO FOR ANY GENERAL SPECIAL OR CONSEQUENTIAL DAMAGES ARISING OUT OF THE SALE OR USE OF ANY PRODUCTS SOLD BY BETSTCO OR AN AGENT THEREOF, BETSTCO MAKES NO WARRANTIES, EXPRESS OR IMPLIED, (INCLUDING, BUT NOT LIMITED TO, ANY WARRANTY OF MERCHANTABILITY OR FITNESS OF THE PRODUCTS FOR ANY PURPOSE) WITH RESPECT TO THE PRODUCTS COVERED BY THIS AGREEMENT EXCEPT AS IN THIS PARAGRAPH OTHERWISE EXPRESSLY PROVIDED.

THIS IS THE SOLE AND ONLY WARRANTY OF VALUE-LEADER PRODUCTS, NO OTHER WARRANTY IS APPLICABLE, EITHE EXPRESSED OR IMPLIED, IN FACT BY LAW.

This warranty shall not be interpreted to render Betstco, or any authorized agent liable for injury or damages of any kind or nature, direct, consequential, or contingent, to a person or property.

The sole and only remedy in regard to any defective product shall be the repair or replacement thereof as herein provided, Betstco, agent(s) of Betstco shall not be liable for any consequential, special, incidental or punitive damages resulting from or caused by any such defects

Betstco reserves the rights to make improvements in design or changes in specifacations at any time, without incurring any obligations to owners of the units previously sold.

WARRANTY VOID IF REGISTRATION IS NOT RECEIVED OR RECORDED ONLINE WITHIN 30 DAYS OF PURCHASE DATE OR SHIP DATE, WHICHEVER IS LATER.

ITEM: _____ **MODEL#** _____ **PURCHASE DATE:** ____/____/____

PURCHASED FROM: _____ **GIFT INV# ORDER#** _____

OWNER NAME: _____ **SERIAL #** _____

OWNER ADDRESS: _____

CITY: _____ **COUNTY:** _____ **ST:** _____ **ZIP:** _____

PHONE: _____ **EMAIL:** _____

ACCEPTANCE OF RESPONSIBILITY:

I (PURCHASER) HAVE READ OPERATORS MANUAL AND LIMITED WARRANTY OR SOMEONE HAS READ/AND EXPLAINED ALL INSTRUCTIONS TO ME. I UNDERSTAND THIS WARRANTY DOES NOT COVER ANY LABOR AND THAT ALL DISPUTES WILL BE SETTLED BY BINDING ARBITRATION. BINDING ARBITRATION IS CONDUCTED BY THE BETTER BUSINESS BUREAU (BBB) LOCATED AT 4004 SW KRUSE WAY PLACE ST 375 LAKE OSWEGO OR 97035 OR THE CURRENT BBB LOCATION CLOSEST TO BETSTCO. I ACKNOWLEDGE MY LIMITED WARRANTY IS VOID IF ANY ATTEMPT TO REPAIR OR REPLACE DEFECTIVE PARTS HAS BEEN MADE BY UNAUTHORIZED PERSONNEL. I ACKNOWLEDGE RECEIPT OF MY OPERATORS MANUAL AND HAVE READ THE SAFE OPERATION SECTION. I ACKNOWLEDGE UNDERSTANDING MAINTENANCE AND SAFE OPERATION REQUIREMENTS, ITEM SPECIFICATIONS, OPERATION, CONTROLS AND STORAGE REQUIREMENTS. **I UNDERSTAND THAT IS ALONE AM RESPONSIBLE FOR PROPER MAINTENANCE, CARE AND SAFE OPERATION OF THIS FARMER-HELPER ITEM**

I (PURCHASER) AGREE THAT PERSONS NOT FAMILIAR WITH THE OPERATION OF THIS ITEM SHOULD NOT BE ALLOWED TO USE IT. CHILDREN ESPECIALLY SHOULD NOT OPERATE OR BE NEAR POWER PRODUCTS WHEN IN USE. ANYONE OPERATING VALUE-LEADER PRODUCTS SHOULD HAVE READ OPERATIONS MANUALS AND SAFETY MANUALS.

OWNERS SIGNATURE: x _____ **DATE:** ____/____/____

YOU MUST SIGN THIS WARRANTY AND MAIL OR FAX A COPY TO BETSTCO, 83371 MELTON RD, CRESWELL OR, 97426. IF YOU PREFER YOU MAY COMPLETE YOUR REGISTRATION ONLINE AT WWW.VALUE-LEADER.COM. THIS WARRANTY IS NOT EFFECTIVE UNLESS PURCHASER COMPLETE REGISTRATION AND WARRANTY FOR WITHIN 30 DAYS OF PURCHASE OR SHIP DATE WHICHEVER IS LATER.

NOTE: WE MAY REFUSE WARRANTY OF ANY KIND UNLESS BETSTCO, RECEIVES A COMPLETED, LEGIBLE AND SIGNED WARRANTY REGISTRATION. IT IS THE RESPONSIBILITY OF THE PURCHASER TO ASSURE THAT REGISTRATION DOCUMENT IS RECEIVED BY

**1 YEAR EXTENDED WARRANTY & REGISTRATION
FARMER-HELPER IMPLEMENTS
BRANDED PRODUCTS
1 YEAR EXTENDED WARRANTY**

1 Year Extended Warranty amends to original Recorded Warranty Registration the time period of described coverage. Extended Warranty does not apply to consumable and Expendable Item as described in Product Warranty Registration.

This amendment does not affect any other part of recorded Warranty Registration or policy.

No one is authorized to alter, modify, or enlarge this Amendment to original recorded Warranty Registration

**EXTENDED REGISTRATION & PAYMENT MUST BE RECEIVED
WITHIN 30 DAYS OF PURCHASE DATE**

EXTENDED WARRANTY REGISTRATION

PRODUCT & MODEL # _____

SERIAL # _____

OWNER NAME : _____

BETSTCO INVOICE # _____

ACCEPTANCE OF RESPONSIBILITY:

I (PURCHASER) HAVE READ AND UNDERSTAND THE EXTENDED WARRANTY OR SOMEONE HAS READ AND EXPLAINED ALL THE ABOVE TO ME. I UNDERSTAND THIS EXTENDED WARRANTY DOES NOT COVER ANY LABOR. I HAVE FILED MY ORIGINAL WARRANTY REGISTRATION AND FULLY UNDERSTAND MY REQUIREMENTS. ***I UNDERSTAND THAT I ALONE AM RESPONSIBLE FOR PROPER MAINTENANCE, CARE AND SAFE OPERATION OF THIS TRACTOR IMPLEMENT.***

OWNERS SIGNATURE: x _____

DATE: ____/____/____

FAX TO 1-541-895-2756

YOU MUST SIGN THIS WARRANTY AND MAIL OR FAX A COPY TO BETSTCO, 83371 MELTON RD, CRESWELL OR. IF YOU PREFER YOU MAY COMPLETE YOUR REGISTRATION ONLINE AT WWW.VALUE-LEADER.COM. THIS WARRANTY IS NOT EFFECTIVE UNLESS PURCHASER COMPLETE REGISTRATION AND WARRANTY FOR WITHIN 30 DAYS OF PURCHASE OR SHIP DATE WHICHEVER IS LATER.

NOTE: WE MAY REFUSE WARRANTY OF ANY KIND UNLESS BETSTCO, RECEIVES A COMPLETED, LEGIBLE AND SIGNED WARRANTY REGISTRATION. IT IS THE RESPONSIBILITY OF THE PURCHASER TO ASSURE THAT REGISTRATION DOCUMENT IS RECIEVED BY BETSTCO.