

PK-AT145 TOWABLE FLAIL MOWER

Pow 'R' kraft



OPERATION & PARTS MANUAL

Please read these instructions before using. Always grease all fittings and be sure to always check and fill with oil before operating! Retain this manual for future use.



www.Betstco.com

541-895-3083 M-F 7am-4pm PST

RUGGED LABOR SAVING EQUIPMENT SINCE 1995 83371 Melton Rd, Creswell OR 97426

Pow 'R' kraft



INDEX

Section:		Description:	Page No:
	1	Introduction	3
		HSE information sheet	4
	2	In the interest of safety: DO NOT	6
	3	In the interest of safety: DO	6
	4	Instruction & Warning Decals	7
	5	Operating Instructions And Adjustments	8
		5.1 Initial Check	8
		5.2 Drawbar Adjustment	9
		5.3 Mower Cutting Height	10
		5.4 Starting The Engine	10
		5.5 Forward Speed	11
		5.6 Stopping The Mower	11
		5.7 Transport Position	11
		5.8 Anti-scalping roller / Side skid's	12
	6	Maintenance Schedule	13
		6.1 Engine	13
		6.2 Excess Crop Build Up	13
		6.3 Visual Check	13
		6.4 tire Pressures	14
		6.5 Rotor Bearing Inspection	14
		6.6 Wheel Bearing Inspection	14
		6.7 Oil Coupling / Bush Wear	14
		6.8 General Inspection	14
		6.9 Rotor Flail Maintenance	14
	7	Parts List	16
	8	Warranty	28

1

INTRODUCTION

With the purchase of your FLAIL MOWER you have made an excellent choice.

This machine should give first class service for a long time, if used correctly, and maintained as described in this manual.

Fitted with an easy to start engine it has been designed to cope with a wide range of conditions. The AT Pull behind Flail mower incorporates easy height adjustment, range of engine options and a full width anti-scalping roller to avoid damage to machine and sward.

The mower is constructed from 4 mm steel for added strength; all fittings are of high quality to ensure years of trouble free use.

Selecting and using equipment for All Terrain Vehicles (ATV's)

Introduction

This information sheet gives advice to users on how to use all Terrain vehicles (ATV's) safely with towed and mounted equipment.

Plan the use of an ATV carefully and take particular note of ground conditions and slopes, as these may vary considerably, depending on the terrain, weather conditions, ground surface and the crop under the wheels.

Towed Equipment

Choose equipment which matches your ATV. Stability of towed equipment is affected by:

Weight Ratios

1. The safe ratio between the trailed loaded maximum weight and unloaded weight of the ATV must be assessed for each operation.
2. Always take note of information given in the manufacture's handbook when making this assessment.
3. As a guide research shows that on level ground, 4 x unloaded weight of the ATV for braked trailed equipment and 2 x unloaded weight of the ATV for un-braked trailed equipment are the appropriate maximum ratios.

Note: For work on slopes or uneven ground the ratio will need to be reduced.

Braking

Fit:

1. Brakes to trailed equipment. This helps prevent jack-knifing when braking or traveling downhill;
2. Over-run brakes which come into action whenever the ATV brakes are applied;
3. A manually operated parking brake operable from the driving position. This provides control for use when going up slopes.

Hitching and Loads

Stability is also improved if:

1. Some weight is transferred from the trailer onto the ATV draw-bar;
2. The draw-bar has a swivel hitch and the ATV a ball hitch having a large head to neck ratio. This makes it easier for the draw-bar hitch to swivel and cope with undulating ground;
3. The load is positioned as near to the center of the trailer as possible.

Tires and Wheels

1. Check tire pressures regularly with a pressure gauge capable of reading low pressures accurately;
2. Check tires regularly for damage and wear;
3. Select equipment which has tires and wheels that can cope with speeds over 20 mph and occasional higher speeds;
4. Use wheels with bead locks on the rims if the main use is going to be on sloping ground. This prevents tire run-off on side slopes.

Maximum Towed Weight

Follow the advice given by manufacturers on the maximum trailed weight. This will be found on the equipment or in the instruction handbook.

Note: Universal road going trailers will normally have the maximum gross weight stated on a separate notice.

Mounted Equipment

ATV's using mounted equipment are safer if the equipment has:

- a low center of gravity. This improves stability.
- a gross weight within the limits approved by ATV manufacturer.
- no dangerous projections to injure the operator or bystanders;
- no forward projections which stop head protection being worn;
- controls which are easy to work and which do not create a hazard to the operator;

Instructions for Mounted and Trailed Equipment

Take note of the manufacturer's instructions on:

- operating on slopes;
- where to place loads so as to give fore/aft and lateral stability;
- the risks of using equipment with negative drawbar nose weight, ie loss of traction;
- the maximum operating speed;
- the effect that equipment carried on front and/or rear racks will have on longitudinal and lateral stability;
- securing loads;
- the use of ballast, if any, to improve stability;
- the need to select and use safe routes.

Using an ATV

- Read the manufacturers's instruction book and take note of the safety advice given;
- Choose an ATV with enough power for the work you want it to do. four-wheel driver will give better traction and mobility and may provide a margin of safety;
- Choose a safe route;
- Be aware that increased speed greatly increases the risk of instability and risk of and overturn;

Training

Train everyone who has to use an ATV whether with mounted or trailed equipment or as a solo machine. The training should emphasize the factors affecting stability, the need for care and concentration, and how to recognize the conditions which may affect the safety of operation, It is important for trainees to familiarize themselves with the handling and control of the machine on level open ground before tackling rough hill terrain.

Suitable training courses are run by bodies such as ATV Landbase and the forestry Authority.

Helmets

Wear head protection which protects the head and neck. Helmets are suitable. Some users find open faced helmets more suitable than full face helmets.



This symbol means **WARNING** or **CAUTION** Personal safety or damage will be at risk if these instructions are ignored. Most accidents are caused by neglect of carelessness; Avoid needless accidents by following the safety precautions listed below.

2

IN THE INTEREST OF SAFETY:DO NOT

1. DO NOT- Operate the mower without all the correct guards fitted.
2. DO NOT- Alter engine settings unless stated by Engine manufacturer.
3. DO NOT- Touch any moving or rotating parts, during working conditions
4. DO NOT- Stop the engine immediately after heavy use, (See section 5.6)
5. DO NOT- Operate the mower without suitable ear and eye protection
6. DO NOT- Allow passengers.
7. DO NOT- Leave machine unattended while operating
8. DO NOT- Run the engine in an enclosed area, exhaust gases contain Carbon Monoxide and are fatal if inhaled.
9. DO NOT- Operate the mower on excessively steep slopes.
10. DO NOT- Operate the mower unless all safety features are fitted to the mower and are used correctly
11. DO NOT- Operate the mower until you have read and understood the entire operators manual
12. DO NOT- Wear loose fitting clothing, to avoid catching on parts of the machine
13. DO NOT- Try to remove blockages while the engine is running. Ensure engine is stopped and the rotor has finished rotating, before any servicing takes place to your mover.
14. DO NOT- Operate the mower in dark conditions unless suitable artificial light is used.
15. DO NOT- Operate if excessive vibration occurs, stop the machine immediately and view maintenance chart.
16. DO NOT- Climb on the mower.

3

IN THE INTEREST OF SAFETY:DO

1. DO- Follow engine manufactures guideline.
2. DO- Ensure all spectators are a safe distance away when operating.
3. DO- Carry out regular servicing and checks before use.
4. DO- Clear cutting area from potential damaging components.
5. DO- Reduce speeds when working on hillsides or rough terrain
6. DO- Be aware components can be hot after operation
7. DO- Follow any towing guidelines stated by ATV manufacturer.
8. DO- Show some caution when filling the tank with fuel, especially if engine components are hot.
9. DO- Ensure all safety decals are in good condition, replace any that are damaged.
10. DO- Keep hands and feet away from rotating blades
11. DO – Ensure mower is in transport position before transporting from workplace.

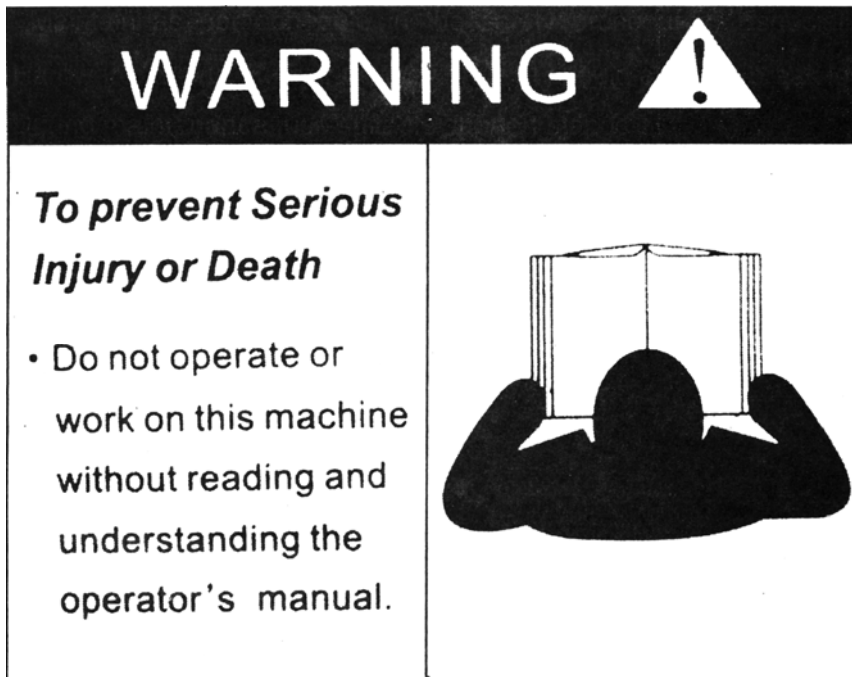

KEEP WHEEL NUTS TIGHT
CHECK DAILY

REFER TO THE OPERATORS MANUAL

FOR CORRECT tire INFLATION PRESSURE

OBSERVE TOWING VEHICLE MAX TOWING LIMITS OR TRAILER MAX WEIGHTS

ATTENTION

Your responsibilities before operating this machine are:

- Read understand and follow the safety procedures manual
- Train operators before using & review safety procedures regularly
- Ensure that all guards are in place before operating
- Keep hands, feet, hair and clothing away from all moving parts
- Avoid wearing loose clothing whenever possible
- Maintain as per schedule in the safety procedures. Especially blades and securing hardware, due to hazard they present should any part break loose during operation
- During maintenance, use suitable support stands
- DO NOT allow any persons to ride on the equipment

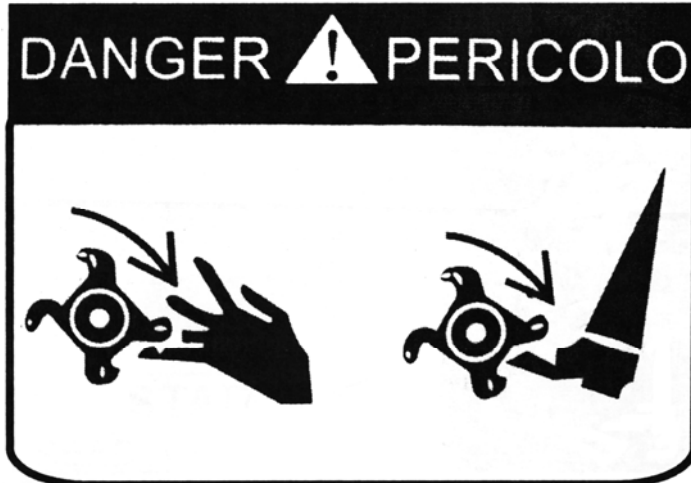
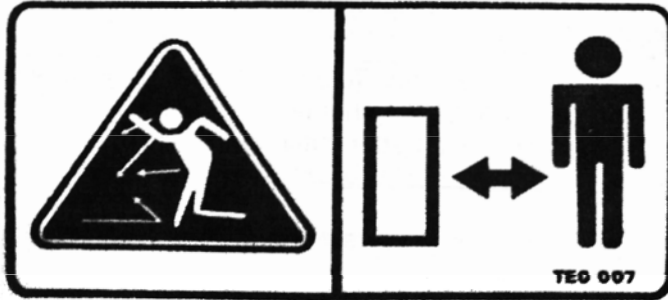

The above decals should be located on your AT – Flail Mower. If any of the above decals are not located on your AT or are damaged in any way contact for some replacement decals before use.

5

OPERATING INSTRUCTIONS AND ADJUSTMENTS

The AT FLAIL MOWER is designed to give safe and dependable service if operated according to instructions and intended use.

Read and understand this manual before operating the mower, as failure to do so could result in personal injury or equipment damage.



When used with and ATV or compact tractor, ear defenders should be worn. Under normal working conditions a noise level of 83 decibels would be usual, in the case protection is advised.

5.1 INITIAL CHECK

1. Make sure that all nuts, bolts and fittings are securely fixed, and that all packaging materials e.g. wire bands, tape etc have been removed. (Remove tape from the front stone deflectors from the underside of the body)
2. Check the there is oil in the engine and petrol in the tank.
3. Check tire pressures.

5.2 DRAWBAR ADJUSTMENT

The drawbar attachment height of the towing vehicle can vary. To accommodate adjustment, a screw link is located beneath the drawbar. This should be lengthened or shortened so that the cutting deck is horizontal to level ground. (This ensures a better cutting efficiency)

TO ADJUST

1. Unlock the locking nut (A)
2. Lengthen the link to lower the front of the deck or shorten to raise the deck.
3. Once the deck is level, re-tighten locking nut (A).

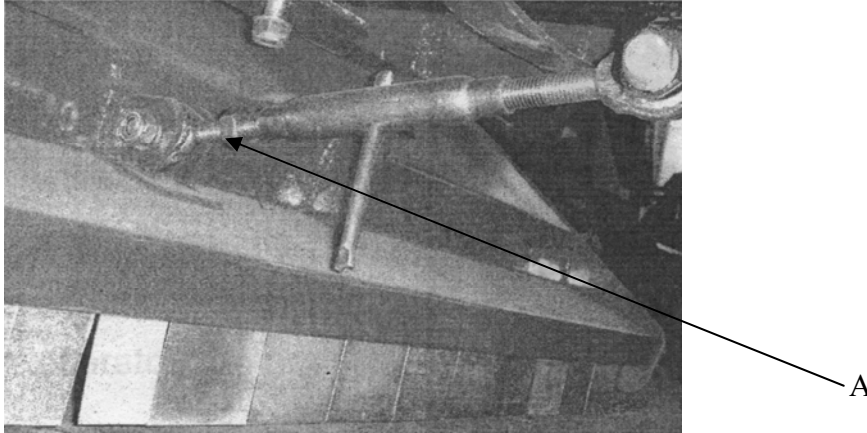

QUICK OFFSET DRAWBAR

Unlock the nut and screw slide the drawbar to the desired position and release the screw into the securing hole then lock the nut, as shown.

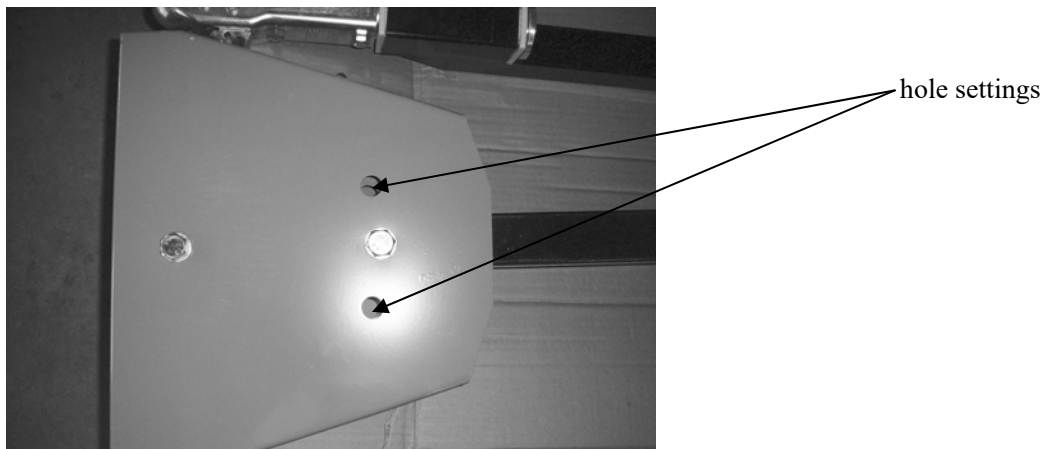

5.3 MOWER CUTTING HEIGHT

The main cutting height adjustment is achieved by using the screw jack, to raise or lower the cutting deck as necessary.

CUTTING HEIGHT ADJUSTMENT:

Turn the handle to raise or lower as necessary.



5.4 STARTING THE ENGINE

READ AND UNDERSTAND THE ENGINE OPERATORS MANUAL BEFORE USE



Observe all safety precautions; keep hands and feet away from rotor and other moving parts. Keep spectators at a safe distance.

1. Make sure there is a gap between the blades and the ground / crop
2. Select an area clear of loose debris that could be picked up.
3. Set the engine choke, and suitable idling speed with the throttle.
4. Place one foot on top of the deck body to give a firm and balanced position. Pull the starter cord firmly, allowing the cord to return to return to the housing slowly (one or two strong pulls should start the engine).
5. After a few seconds warming up at idling speed, move the throttle to the factory pre-set working position to give a normal/working engine R.P.M of 3600 max.

NOTE



If the throttle is altered to increase the engine R.P.M beyond the recommended level, the guarantee may become invalid. In addition to this, cutting efficiency will be reduced, fuel consumption will increase and excessive vibration could be caused, resulting in a potential danger to personnel and damage to components.

ELECTRIC START

Push button electric start engine options can be supplied if required. Simply hitch up the mower, connect the electrical supply plug to the ATV socket and turn the ignition key to start the mover. Observing all the precautions mentioned above in 'Starting the mower'.

REMOTE THROTTLE CONTROL

When a remote throttle control option is fitted, normally to the rear carrier frame of an ATV or other suitable site on the towing vehicle, it gives the operator the facility of controlling the

mower engine from the operating position.

The facility is most beneficial when moving from one cutting site to another close to it, by reducing the engine revs to allow the mower flails to come to rest, no harm will be caused to the mower or ground surface during transport, often over rough or difficult terrain when stones and loose objects may be encountered.

5.5 FORWARD SPEED

The amount of grass or weeds to be cut dictates the forward speed; slow forward speeds give better results in most cases. Ensure you follow the procedure below.

NORMAL FORWARD SPEED (1 kph- very heavy use- 10 kph - very light use)

Start off in the slowest speed possible, ensure the mower is working efficiently with the engine set at maximum RPM and not laboring. (If this is not possible due to very heavy cutting conditions, raise cutting height of blades and be prepared to go over twice with machine set lower on 2nd pass, leave at least 24 hours in between 1st and 2nd cut to allow grass to dry out)

Increase forward speed until the RPM of the engine starts to slow down (This is working the engine too hard for conditions) – slow down, let the engine regain full RPM and go through the same process but stop short of speed which made engine labor previously. It is important always to listen to note of engine to ensure engine and mower are working efficiently, slow down or stop once engine starts to labor.

FAILURE TO DO THIS WILL RESULT IN CLUTCH SLIP AND ULTIMATELY SEVERE DAMAGE TO THE CLUTCH AND DRIVE BELTS.



When moving from normal working conditions to heavier cutting, it may be evident that the engine dies down and loses revs. **SLOW DOWN IMMEDIATELY** to allow the engine revs to build up again to normal working speed. Follow the procedure detailed above in “Normal Forward Speed”. Expected forward speed will be much lower in heavy conditions.

**FAILURE TO DO THIS WILL RESULT IN CLUTCH SLIP AND
ULTIMATELY
SEVERE DAMAGE TO THE CLUTCH AND DRIVE BELTS.**

5.6 STOPPING THE MOWER

When stopping the mower after a period of heavy use. Run the machine at half working speed in a stationary position, for at least 4 minutes, to allow the drive belts to cool down.

1. Show caution to hot parts e.g. engine exhaust, belts etc after engine is switched off.
2. Ensure the mower drawbar has been adjusted to allow the mower to run directly behind the towing vehicle and is not in an offset position
3. When the mower has cooled down (Min 1 hr after last used) Ensure all grass has been removed from engine cooling fins, drive belt area, and rotors before operating again.

5.7 TRANSPORT POSITION

When the mower is being moved from one site to another it is advisable to raise the deck to the highest position (Transport position, See section 5.3 “Mower cutting height”)

The engine must be stopped and the blades at a standstill before adjusting to the transport position.

Remove any crop debris from the deck before leaving the field.

Never move from one site to another with the engine running.

Please note the AT – Flail Mower is not road legal, and should not be used on public roadways

5.8 ANTI-SCALPING ROLLER/SIDE SKIDS

The main purpose of the anti scalping roller is to prevent damage .If a wheel drops into a hole, or there is uneven ground between the wheels, the roller takes the weight of the mower, avoiding the flails scalping the ground;combined with the side skids the mower provides good protection to the rotor.

The anti scalping roller has the added advantage of-enabling curb side grass to be cut with no difficulty, by allowing the wheel to hang over the curb edge.

The factor pre-set position of the anti scalping roller and side skids are suitable for most situations.

However, if the mover is used in rough conditions or regularly in heavy crops, the roller and side skids should be lowered, to increase the clearance between the flail and the ground when the roller comes into use.

In circumstances where the mower is being used as a “Finishing Mower” and a striped appearance is desired, the roller can be set down using the various hole positions to give the required cutting height, then the wheels can be lifted clear of the ground.

TO ADJUST THE ROLLER:

Slacken pivot bolt “A”.

Slacken and remove bolt

“B”(Repeat for both ends of the roller)

Select another hole and

Replace bolt “B”. Tighten bolts “A” and “B”

TO ADJUST THE SIDE SKIDS:

Remove the bolt at the

Front of the skid and the rear of the skid (show as “C”) Select new setting, replace the bolts and tighten. Repeat for the opposite skid; always ensure both skids are set to

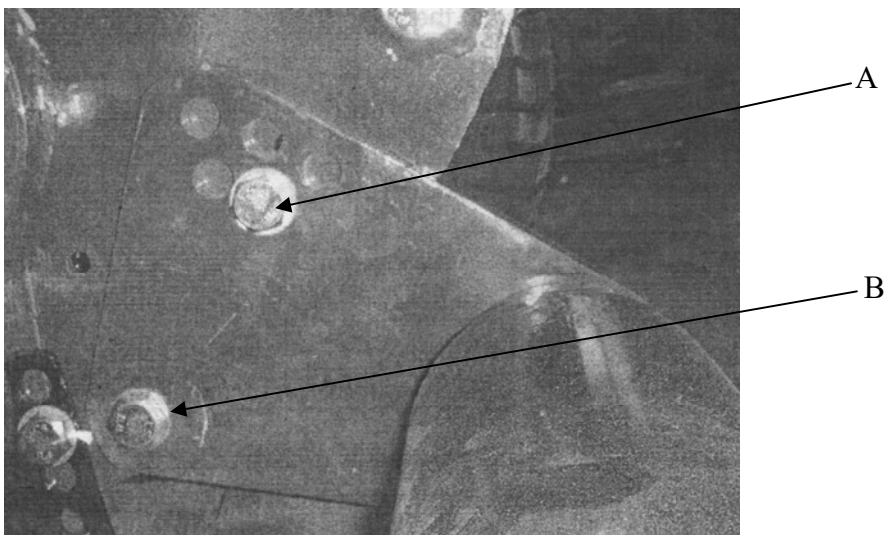

6

MAINTENANCE

Maintenance Schedule				
Maintenance Operation:	Hourly	Daily	Weekly	Seasonal
Engine (See Engine manufacturers manual)	•	•	•	•
Remove excess crop gathered on deck	•	•	•	•
Remove excess crop wrapped around rotor ends	•	•	•	•
Visual check to ensure nothings loose		•	•	•
Grease Height Adjuster		•	•	•
Grease Rear Roller		•	•	•
Grease Rotor Bearings		•	•	•
tire Pressures			•	•
Drive belt inspection			•	•
Rotor Bearing inspection			•	•
Wheel bearing inspection			•	•
Oil 50 mm coupling			•	•
Swivel hitch Bush Wear			•	•
Check All Fasteners are tight and intact			•	•
Safety Chain Guard inspection			•	•
Safety Decals intact			•	•
Safety Guards Intact			•	•
Check Blade wear / condition				•
Check Metal Fatigue				•
Clutch Wear / Function				•

6.1 ENGINE

Refer to engine manufacturers manual, for servicing and maintenance of the engine.

6.2 EXCESS CROP BUILD UP

Remove all crop deposits from the deck, and engine area. Build up of crop deposits could result in heat build and fires

Disconnect the spark plug lead.

Remove any crop that is wrapped around the end of the rotor (A) or on the underside of the deck. Raise the deck to its max height to assist access to the rotor shaft.

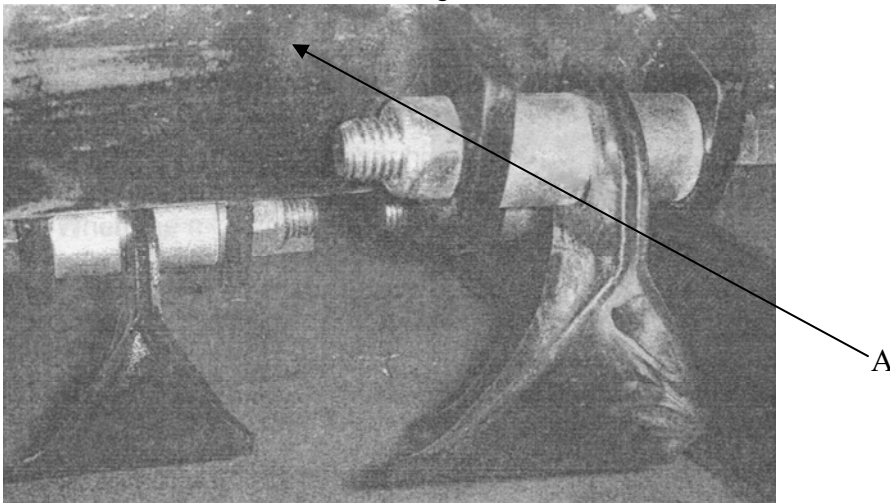

6.3 VISUAL CHECK

Make a visual check around the mower, check for missing / loose parts or damaged / worn components. All-faults must be either repaired or replaced. Check and tighten all nuts and bolts prior to each use. Lube all moving parts before each use as well.

6.4 TIRE PRESSURES

DO NOT exceed recommended type pressures		
22×1100	-8	7 – 10 PSI
16.5×6.50	-8	28 PSI (Max)

6.5 ROTOR BEARING INSPECTION

Rotate rotor shaft by hand and feel for any roughness in the bearings. Also try to pull the shaft from side to side to see if any movement is found. If symptoms persist strip down the rotor-housing unit and inspect bearings.

6.6 WHEEL BEARING INSPECTION

Jack one side of the mower body up, so the wheel is just off the ground. Rotate the wheel by hand, and check the wheel alignment. To check the bearing, try to move the wheel from left to right and feel for any play in the bearings (A), ensure the wheel-locating bolt is tight before you start and follow any jacking procedures. If any play is found remove the wheel and

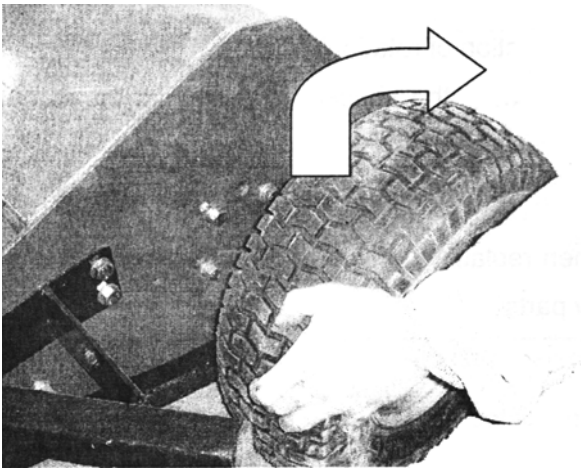

6.7 OIL 50 mm COUPLING/BUSH WEAR

Check coupling for signs of damage or wear, swivel the coupling 36. degrees and check that the bushes are not too worn. Replace any worn or damaged parts.

Oil the coupling regularly as shown below.

6.8 GENERAL INSPECTION

Check the mower to ensure all fasteners are tight and all safety guards / chains are intact and fitted securely. Check all safety-warning decals, Replace any defective guards or damaged decals.

6.9 ROTOR FLAIL MAINTENANCE

The AT range has “Rock” knives designed to last a long time. The standard knives are double edged for even longer life. However, when breaking or losing a knife, it is important to replace it immediately. Failure to do this can cause serious unbalancing problems. (Always use spare parts)

At the time of replacement, the opposite knife on the rotor should be checked for wear. If it is partially or well worn then it should be changed to maintain an accurate weight balance.

When the first cutting edge is becoming blunt, the whole set of flails should be turned around. (Using blunt knives will reduce the cutting efficiency and increase fuel consumption).

Replacing or reversing the knives follows this simple procedure:

- (A) Ensure mower engine has stopped and the knives have stopped rotating. Switch off the fuel tap and let the machine cool down for 5 minutes. Remove the spark plug to ensure the engine cannot be started.
- (B) Raise the mower to its max cutting height.
- (C) Carefully raise the drawbar to an incline position, so that height adjuster bar at the rear of the mower takes the weight. NB; Do not attempt this with the wheels behind version; raise the front jack to its max height.
- (D) Slacken and take out the shackle bolt.
- (E) Replace or turn around blades (Note the direction of rotation)
- (F) Replace shackle bolt securely, but still allowing the shackle to swing on the fixing bush.

NOTE:

Never use cracked or repaired shackles when replacing knives. If the shackle fixing has become damaged or worn, replace with new parts



For repairs beyond the minor adjustments listed above, contact your local dealer or contact.

Your PK-AT Flail accepts only EF and EFG series

Flail Mower Blades

1. EF & EFG Grass Blades - Suitable for field grass mowing.
2. EF Mulcher Blades - Suitable for grass or light brush. May be sharpened and used for lawn grooming.
3. EFG Hammer Blades - Suitable for mowing and mulching
Grass & Brush, up to 2" diameter material.
4. EFGC Grass Blades - Suitable for field grass mowing.
5. EFGC Hammer Blades - Suitable for mowing and mulching
Grass & Brush, up to 3" diameter material.



ATV Flail Mower Assembly

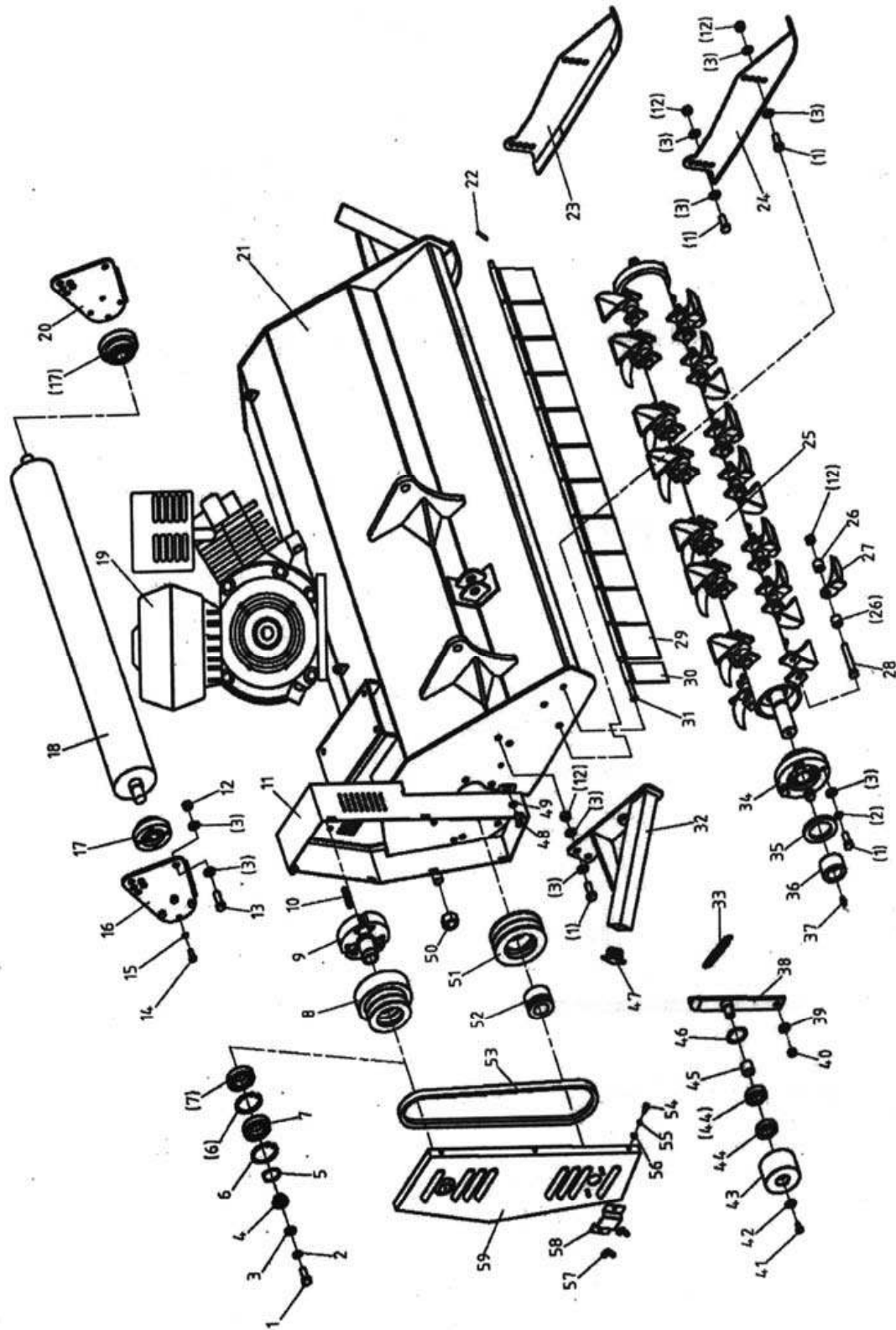

ATV Flacil Mower Assembly

NO.	Part NO.	Name & Specifications	Quantity	Remark
1	GB5783-86	M12x30 Blot M12x30	19	
2	GB93-87	12 Spring washer 12	9	
3	GB97.1-85	12 Plain washer 12	37	
4	MFP120.00.106	Fixing sleeve	1	
5	GB894.1-85	35 Circlip 35	1	
6	GB893.1-86	62 Circlip 62	2	
7	GB278-89	6007Z Bearing 6007Z	2	
8	MFP120.00.152	Driving Belt wheel	1	
9	MFP120.00.017	Clutch	1	
10	GB1096-79	6.3x7x50 Key 6.3x7x50	1	4898682120
11	MFP120.00.018	Protecting for transmission	1	
12	GB6184-86	M12 Locking nut M12	42	
13	GB5783-86	M12x35 Blot M12x35	4	
14	GB5783-86	M8x20 Blot M8x20	8	
15	GB93-87	8 Spring washer 8	8	
16	MFP120.00.155	Supporting plate (R)	1	
17	EF100.00.012	UC205 Bearing UC205	2	
18	RK120.017	Roller weldment	1	
19	JF390	Gasoline engine	1	
20	MFP120.00.156	Supporting plate (L)	1	
21	MFP120.00.012	Deck weldment	1	
22	GB91-86	4X28 Split pin 4x28	1	
23	MFP120.00.026	Adjusting plate (R)	1	
24	MFP120.00.025	Adjusting plate (L)	1	
25	RK120.020	Blade axle	1	

ATV Flail Mower Assembly

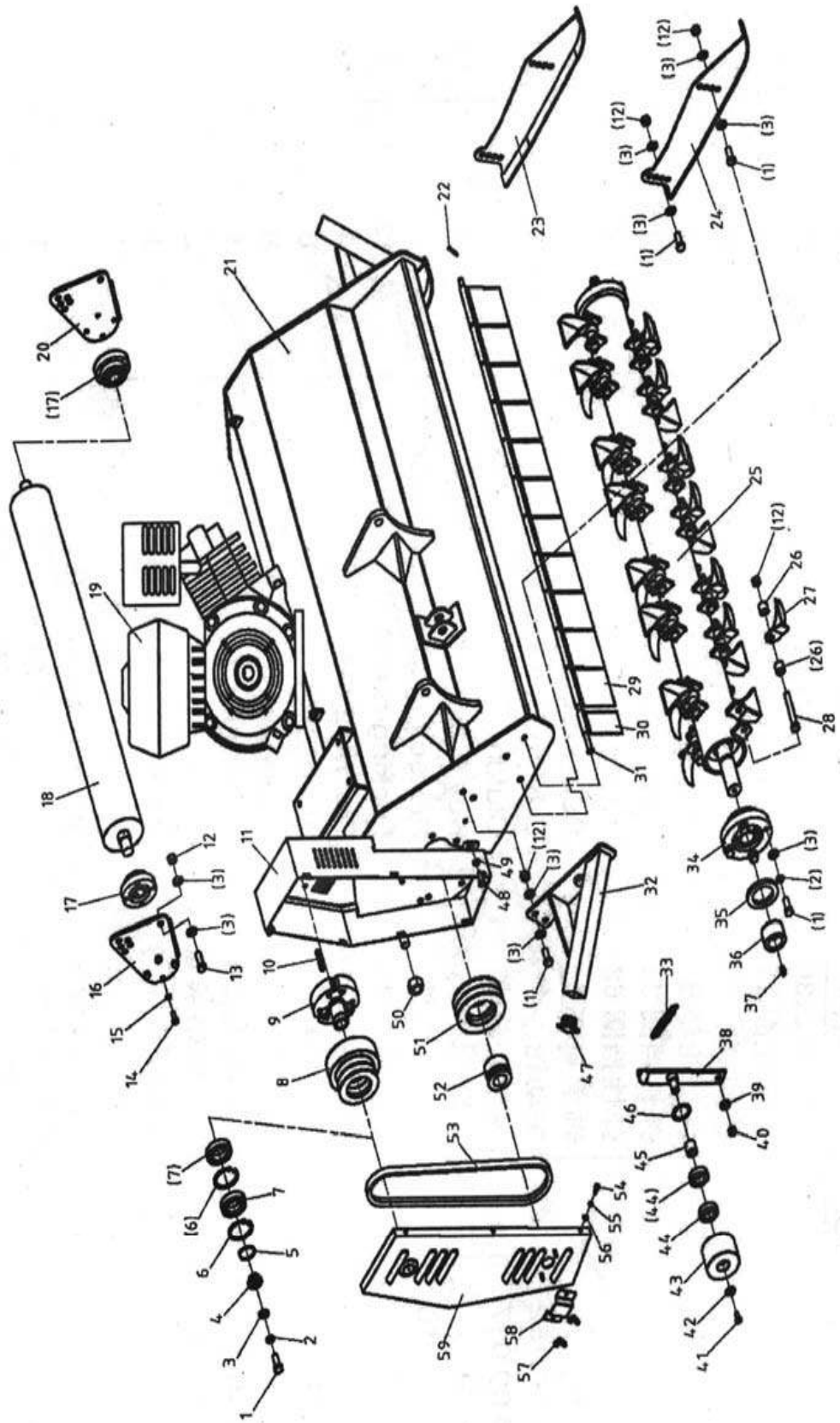

ATV Flacil Mower Assembly

NO.	Part NO.	Name & Specifications	Quantity	Remark
26	EF100.00.101	Sleeve	56	
27	RK120.114a	Blade	28	
28	GB5782-86	Blot M12x80	28	
29	EF100.00.122	Baffle	12	
30	EF100.00.121	Baffle	1	
31	MFP120.00.109	Shaft	1	
32	MFP120.00.024	Protecting bracket	2	
33	MFP120.00.116	Tension spring	1	
34	UC207-Z	Bearing seat 90207	2	
35	GB13871-94	Oil seal FB55x80x8	2	
36	RK120.109	Oil-sealing sleeve	2	
37	GB1152-89	Oil cup M8x1	1	
38	MFP120.00.036	Bracket for tension spring	1	
39	GB97.1-85	Plain washer 10	1	
40	GB6184-86	Locking nut M10	1	
41	GB5783-86	Blot M8x16	1	
42	GB96-85	Plain washer 8	1	
43	MFP120.00.153	Tensioner	1	
44	GB279-88	Bearing 180105	2	
45	MFP120.00.154	Sleeve	1	
46	GB893.1-86	Circlip 47	1	
47	MFP120.00.101	Cover	2	
48	GB5783-86	Blot M8x25	2	
49	GB97.1-85	Plain washer 8	2	
50	GB6184-86	Locking nut M20	2	

ATV Flail Mower Assembly

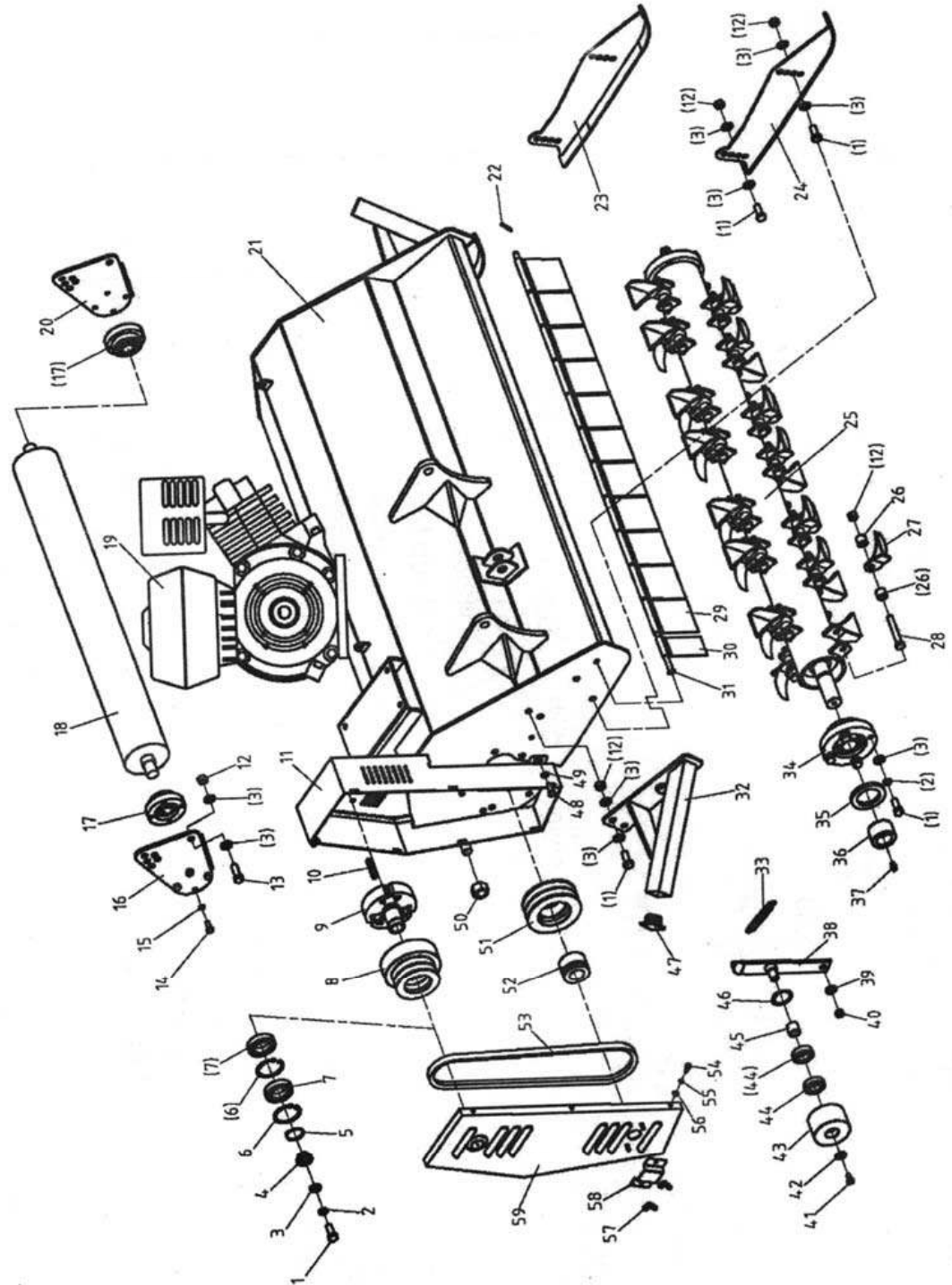

ATV Flacil Mower Assembly

NO.	Part NO.	Name & Specifications	Quantity	Remark
51	MFP120.00.107	Driven belt wheel	1	
52	JB/T7934Z3	REACH 04 35X60 Swellable sleeve	1	
53	GB12732	V B 1067 Belt 1067	2	
54	GB5783-86	M6X16 Bolt M6x16	7	
55	GB93-87	6 Spring washer 6	7	
56	GB97.1-85	6 Plain washer 6	7	
57	GB62-88	M6 Butterfly nut M6	2	
58	MFP120.00.111	Cover plate	1	
59	MFP120.00.011	Protecting cover	1	

Wheel Partment Assembly

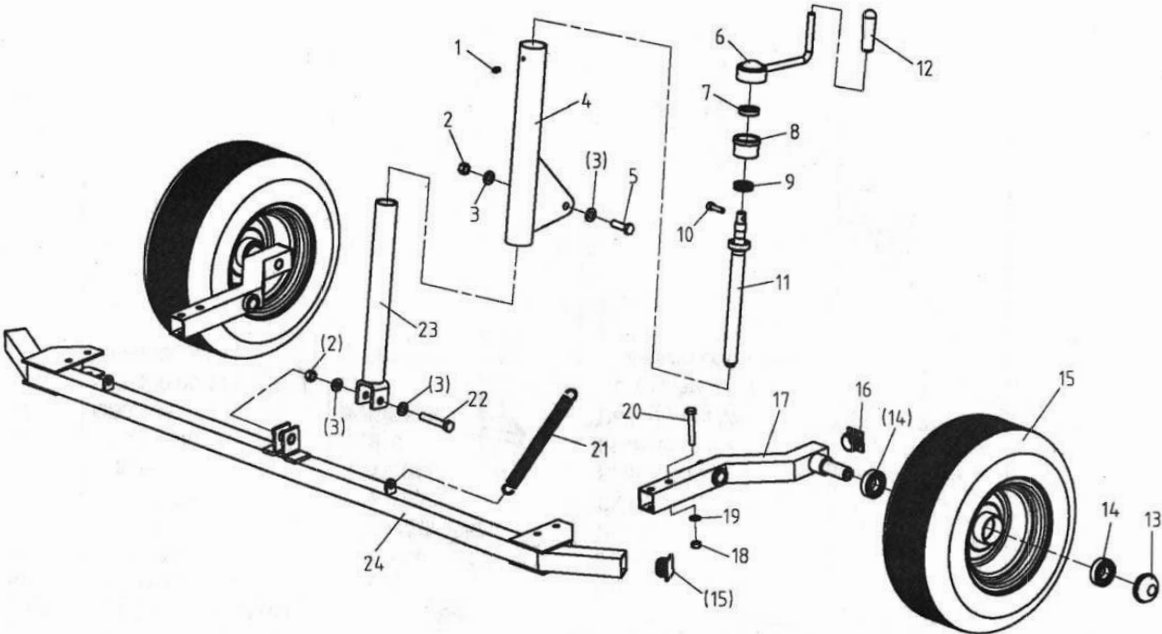

Wheel Partment Assembly

NO.	Part NO.	Name & Specifications	Quantity	Remark
1	GB1152-89	M6 Oil cup M6	1	
2	GB6170-86	M12 Mut N12	2	
3	GB97.1-85	12 Plain washer 12	4	
4	MFP120.00.038-A	Protection casing weldment	1	
5	GB5783-86	M12x35 Bolt M12x35	1	
6	MFP120.00.039	Handle	1	
7	GB276-94	61904 Bearing 61904	1	
8	TR200.00.123	Bearing seat	1	
9	GB301-95	51104 Bearing 51104	1	
10	GB70-85	M8x30 Screw M8x30	1	
11	TR200.00.120	Adjusting screw	1	
12	MFP120.00.176	Sheath for handle	1	
13	MFP120.00.148	Cover for tire	2	
14	GBT278-94	80205 Bearing 80205 tire	4	
15	MFP120.00.016	Rubber cover	2	
16	MFP120.00.101	Supporting bracket for tire	4	
17	MFP120.00.027	Nut M10	2	
18	GB889-86	10 Plain washer 10	4	
19	GB97.1-85	M10x65 Blot M10x65	4	
20	GB5782-86	Tension spring	4	
21	MFP120.00.115	M12x70 Bolt M12x70	2	
22	GB5782-86	Adjusting coil	1	
23	MFP120.00.037-A	Crossbeam weldment	1	
24	ATV120.028			

Traction Assembly

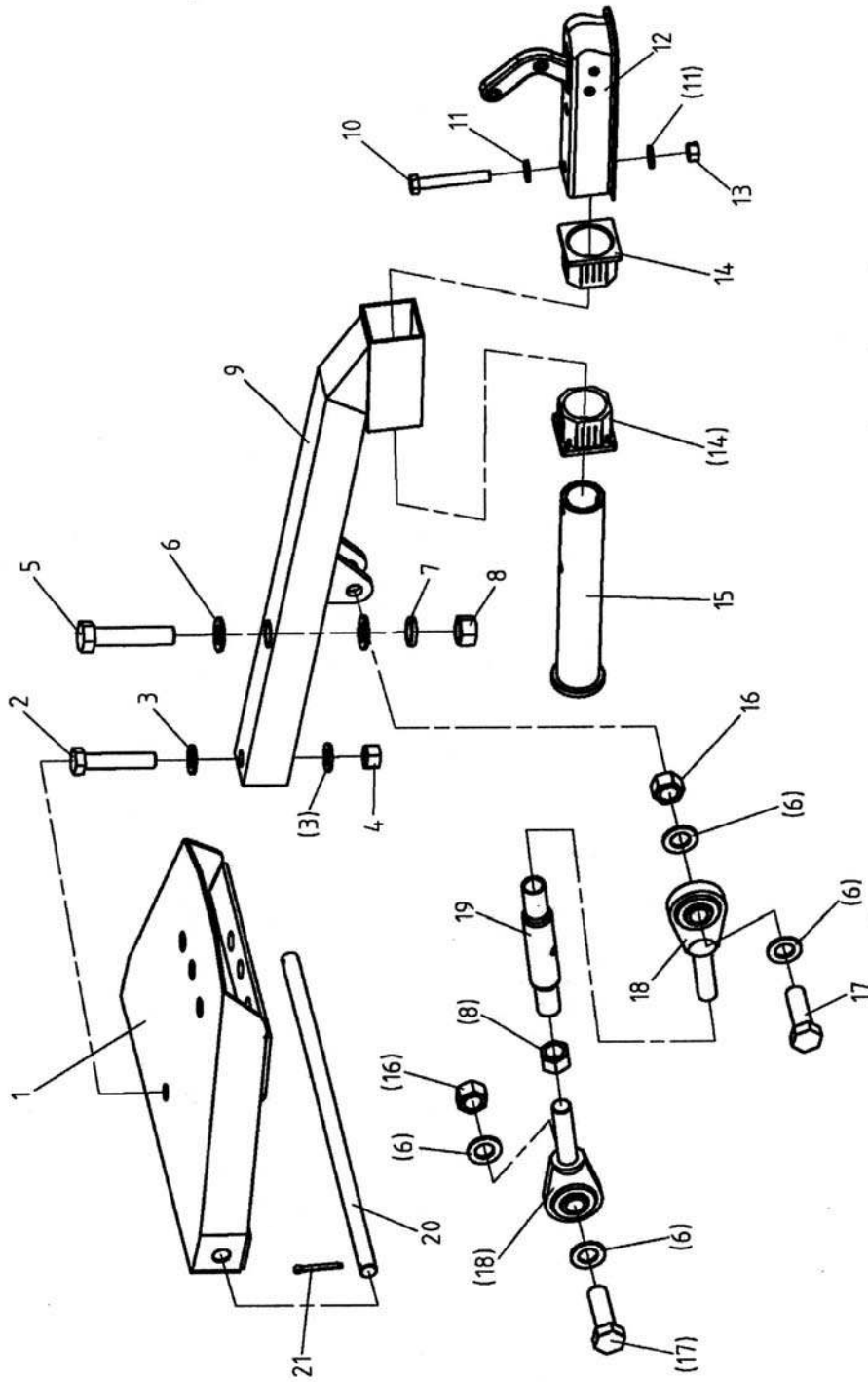

Traction Assembly

NO.	Part NO.	Name & Specifications	Quantity	Remark
1	ATV120.013	Soleplate weldment	1	
2	GB5782-86	M16x80 Blot M16x80	1	
3	GB97.1-85	16 Plain washer 16	3	
4	GB184-86	M16 Locking nut M16	1	
5	GB5782-86	M20x90 Blot M20x90	1	
6	GB97.1-85	20 Plain washer 20	5	
7	GB93-87	20 Spring washer 20	1	
8	GB6170-86	M20 Nut M20	2	
9	ATV120.00.015	Bracket for traction	1	
10	GB5782-86	M12x80 Blot M12x80	2	
11	GB97.1-85	12 Plain washer 12	4	
12	GM8835	Hook for traction	1	
13	GB6184-86	M12 Locking nut M12	2	
14	7CB-0.25-131	Axle sleeve	2	
15	7CB-0.25-129	Shaft tube for traction	1	
16	GB6184-86	M20 Locking nut M20	2	
17	GB5783-86	M20x65 Blot M20X65	2	
18	MFP120.00.014-1	Lifting handle	1	
19	MFP120.00.014-2	Lifting coil	1	
20	MFP120.00.102	Pin shaft	1	
21	GB91-86	5X32 Split pin 5x32	2	



Parts Request Form

Fax to 541-895-2756

Name: _____

Address: _____

City State Zip: _____

Phone: _____

E-mail: _____

Model Number: _____
Serial Number: _____
Purchased From: _____
Purchase Date: _____

Item No.	Description	Qty	Price	Amount

Comments:

BETSTCO, FARMER-HELPER, POWRKRAFT, VALUE-LEADER
LIMITED 1-YEAR WARRANTY

Unless otherwise stated on purchase invoice, Betstco warrants to original Purchaser that its products are free from major defects in material under normal use and service for a period of one (1) Year from the date the product is purchased or shipped, whichever is later. Commercial use 60 days. Use at address that is not yours, is considered commercial use. Warranty does not cover Consumable, Expendable, Wear Items (Examples:Rubber & plastic parts, hydraulic hoses, belts, tires, cables, blades, tines, wedges, teeth, tips, chains, pins, brushes, filters, etc.) and cracked hydraulic pumps, bent or broken cylinder rods are not covered under this warranty. Warranty does not cover items that have been modified, damaged by abuse or usage not in accordance with design or maintenance.

Betstco obligation under this warranty is to repair or replace defective product upon approval by; Betstco, 83371 Melton Rd. N., Creswell OR 97426 that Warranty Claim is Valid. Product shall be returned upon request of Betstco. Transportation charges to be prepaid by buyer. Replacement parts are subject to the supply conditions at the time of repair or replacements, which may directly affect our ability to obtain material and/or replacements parts. **Gasoline or diesel engines used to power products are covered by the warranty of the appropriate engine manufacture and Purchaser must look to the engine manufacture for all issues relating to engine operation.**

Betstco assumes no responsibility for outside labor.

PERMISSIBLE BY APPLICABLE LAW, BETSTCO HEREBY DISCLAIMS ALL WARRANTIES OF ANY KIND, EITHER EXPRESS OR IMPLIED, INCLUDING, ANY IMPLIED WARRANTIES WITH RESPECT TO THE PRODUCT PURCHASED, WITHOUT LIMITING THE GENERALITY OF THE FOREGOING, BETSTCO HEREBY EXPRESSLY DISCLAIMS ALL LIABILITY FOR PRODUCT DEFECT OR FAILURE, CLAIMS THAT ARE DUE TO NORMAL WEAR, PRODUCT MISUSE, ABUSE, PRODUCT MODIFICATION, IMPROPER PRODUCT SELECTION, NON-COMPLIANCE WITH ANY CODES, OR MISAPPROPRIATION. BETSTCO MAKES NO WARRANTIES TO THOSE DEFINED AS "CONSUMERS" IN THE MAGNUSON-MOSS WARRANTY-FEDERAL TRADE COMMISSION IMPROVEMENTS ACT. THE FOREGOING EXCLUSIONS OF IMPLIED WARRANTIES DO NOT APPLY TO THE EXTENT PROHIBITED BY LAW. PLEASE REFER TO YOUR LOCAL LAWS FOR ANY SUCH PROHIBITIONS THIS WARRANTY SHALL NOT BE INTERPRETED TO RENDER BETSTCO, OR ANY AUTHORIZED AGENT LIABLE FOR INJURY OR DAMAGES OF ANY KIND OR NATURE, DIRECT, CONSEQUENTIAL, OR CONTINGENT, TO PERSON OR PROPERTY ARISING OUT OF THE SALE OR USE OF ANY PRODUCTS SOLD BY BETSTCO OR AN AGENT THEREOF. BETSTCO MAKES NO WARRANTIES, EXPRESS OR IMPLIED, (INCLUDING, BUT NOT LIMITED TO, ANY WARRANTY OF MERCHANTABILITY OR FITNESS OF THE PRODUCTS FOR ANY PURPOSE) WITH RESPECT TO THE PRODUCTS COVERED BY THIS AGREEMENT EXCEPT AS IN THIS PARAGRAPH OTHERWISE EXPRESSLY PROVIDED. THIS IS THE SOLE AND ONLY WARRANTY OF BETSTCO, FARMER-HELPER, POWRKRAFT OR VALUE-LEADER PRODUCTS, NO OTHER WARRANTY IS APPLICABLE, EITHER EXPRESSED OR IMPLIED, IN FACT OR BY LAW.

The sole and only remedy in regard to any defective products shall be the repair or replacement thereof as herein provided. Betstco, agent(s) of Betstco shall not be liable for any consequential, special, incidental or punitive damages resulting from or caused by any such defects.

Betstco reserves the right to make improvements in design or changes in specifications at any time, without incurring any obligations to owners of units previously sold.

No one is authorized to alter, modify, or enlarge this warranty nor the exclusions, limitations, and

[Betstco Revision 11-15-2017](#)

WARRANTY VOID IF REGISTRATION IS NOT RECEIVED OR RECORDED ONLINE WITHIN 30 DAYS OF PURCHASE DATE OR SHIP DATE, WHICHEVER IS LATER.

REGISTRATION

Item _____ Model # _____ Purchase Date ____/____/____

Purchased From: _____ Gift Inv#/Order# _____

Owner Name: _____ Serial # (if Applicable) _____

Owner Address: _____

City: _____ County: _____ ST: _____ Zip Code: _____

Phone: _____ Email: _____

Acceptance of responsibility:

I (Purchaser) have read operators manual and Limited Warranty or someone has read/and explained all instructions to me. I understand this warranty does not cover any labor and that all disputes will be settled by binding arbitration. Binding arbitration is conducted by the Better Business Bureau (BBB) located at 4004 SW Kruse Way Place Ste 375 Lake Oswego OR 97035 or the current BBB location closest to Betstco, I acknowledge my Limited Warranty is void if any attempt to repair or replace defective parts has been made by unauthorized personnel. I acknowledge receipt of my Operators Manual and have read the Safe Operation Section. I acknowledge understanding maintenance and safe operation requirements, item specifications, operation, controls, and storage requirements. **I understand that I alone am responsible for proper maintenance, care and safe operation of this Pow'R'kraft item. I understand that this warranty DOES NOT cover supplier equipment such as engines.**

___ Received and read Operators Manual, Specifically Safe Operation Section. ___ Specifications Accepted

___ Controls Understood ___ Maintenance Requirements Understood ___ Proper Storage Understood

I (Purchaser) agree that persons not familiar with the operation of this item should not be allowed to use it. Children especially should not operate or be near Power Products when in use. ANYONE OPERATING POW'R'KRAFT PRODUCTS SHOULD HAVE READ OPERATIONS MANUALS AND SAFETY MANUALS.

Owners Signature: x _____ Date: ____/____/____

You must sign this warranty and mail or Email to Betstco, 83371 Melton Rd, Creswell OR 97426. Email: Cservice@betstco.com. This warranty is not effective unless the Purchaser completes Registration and Warranty Form within 30 days of purchase date or ship date whichever is later.

NOTE: We may refuse warranty of any kind unless Betstco, receives a completed, legible and signed warranty registration. It is the responsibility of the purchaser to assure that registration document is received by Betstco.

Online Registration available at Betstco.com

Betstco / Pow'R'kraft

2 YEAR EXTENDED WARRANTY & REGISTRATION

Pow'R'Kraft Branded Products

2 YEAR EXTENDED WARRANTY

2 Year Extended Warranty amends to original Recorded Warranty Registration the time period of described coverage. Extended Warranty does not apply to Consumable and Expendable Items as described in Product Warranty Registration.

This Amendment does not affect any other part of recorded Warranty Registration or Policy.

No one is authorized to alter, modify, or enlarge this Amendment to original recorded warranty registration.

EXTENDED REGISTRATION & PAYMENT MUST BE RECEIVED WITHIN 30 DAYS OF PURCHASE DATE

EXTENDED WARRANTY REGISTRATION

Product & Model # : _____

Serial #: _____ if applicable

Owner Name: _____

Sellers Invoice/Order # _____

Acceptance of responsibility:

I (Purchaser) have Read and understand the Extended Warranty or someone has read/and explained all the above to me. I understand this extended warranty does not cover any labor. I have filed my Original Warranty Registration and fully understand my requirements. **I understand that I alone am responsible for proper maintenance, care and safe operation of this equipment.**

I (purchaser) also understand that persons not familiar with the operation of this equipment should not be allowed to use it. Children especially should not operate or be near equipment. ANYONE OPERATING EQUIPMENT SHOULD HAVE READ ALL EQUIPMENT OPERATIONS MANUALS AND SAFETY MANUALS..

Owners Signature: x _____

Date: _____

You must sign this extended warranty and mail copy to Betstco, 83371 Melton Rd, Creswell OR 97426. This extended warranty is not effective unless the Purchaser faxes or mails this Registration Form within 30 days of purchase. NOTE: The Manufacturer may refuse warranty of any kind unless Betstco receives a completed, legible and signed extended warranty registration. It is the responsibility of the purchaser to assure that this registration document is received by Betstco.

To determine Payment for Extended Warranty Call: Betstco @ 541-895-3083