

# GK SERIES

# Value Leader

est.1995



## OPERATION & PARTS MANUAL

*Please read these instructions before using. Always grease all fittings and be sure to always check and fill with oil before operating! Retain this manual for future use.*

**BETSTCO**

[www.Betstco.com](http://www.Betstco.com)

541-895-3083 M-F 7am-4pm PST

RUGGED LABOR SAVING EQUIPMENT SINCE 1995 83371 Melton Rd, Creswell OR 97426



*Specifications subject to change without notice*

## General Safety Information

Ensure all potential operators read this manual thoroughly before using the machine

**Safety:** Ensure tractor and machine is stopped & keys out of ignition before set-up/maintenance

**Safety:** Failure to follow good safety standards could result in severe injury or even death

**Misuse:** This machine is designed for use with compact tractors, and should be used only for the indicated purpose. We does not take responsibility if the machine is used for any otne purpose. Children must not operate the machine under any circumstance.

**Modification:** Do not modify equipment in anv way. This may impair the operation and overall safety of the machine.

Tractor requirements: Use only with compact tractors within power range specified.

**Misuse transport:** Do not use machinery to transport personnel or livestock.

**Condition:** For the safety of personnel and optimum performance of the machine, you should check the condition of the machine and the tractor before starting. Before use check all nuts and bolts are tight.

**Spatial awareness:** Always check the operating area is safe before starting machinery.

**Operator clothing:** The operator should not wear loose clothing while operating machinery.

**Safety wear:** Always use appropriate ear protection when running a tractor and machinery  
Ensure you are wearing protective gloves when servicing and using machinery.

**Bystander safety:** Ensure bystanders keep away from the machine when it is in use. Do not touch moving parts when the machine is at work.

**Public places:** When traveling on the road/public places, always keep the PTO turned off

**Maintenance:** Always keep the machine maintained and in a good state. Where necessary repair or replace any defective parts. Do not modify the machine.

**Sharp objects:** Pay attention to the sharp/pointed parts while servicing the machine.

**Safety guards:** All protective parts should be in good condition before operating machinery.

**Safety signs/stickers:** Keep all safety signs clean and legible. Replace anywhich are missing or illegible. If a component with safety sign/(s) is replaced, make sure new safety sign/(s) are attached in the same locations.

**Operating speeds:** Machinery and PTO should be operated at the recommended speed at all times.

**Safety awareness:** Good safety requires that you familiarise yourself with various safety signs, the type of warning and the area, or particular function related to that area.

**Alertness:** Never consume alcohol or drugs these can hinder alertness/coordination. Consult your doctor about using this machine while taking prescription medications.

## **Machinery Pre-Use Checks**

On receipt of your new machine and again within the first 4 hours of use, or the 'shake in' period as we like to call it, we always recommend checking over the machine.

- Check all bolts, Nuts and Screws are tight on the unit.
- Tighten/Check any bolts and nuts securing blades.
- If your machine has belts, check the tension and adjust if required.
- Apply grease to grease points if necessary.
- Check gear oil level. Do not overfill

## **Tractor Pre-Use Checks**

- Check that the machine is properly attached to the tractor. Ensure that secure pins are used on the linkage mounting pins.
  - Be sure to add extra weights to the front of the tractor or add wheel weights if required.
  - Check that the tractor PTO shaft turns freely and that the machine's PTO drive shaft can extend easily. Grease the PTO drive shaft using the grease points.
  - The chain on the PTO shaft should be checked and in a good condition. The universal joints installed should be in a good state with proper protective parts.
  - Before installing the PTO shaft, the tractor and machine should be stopped and the key removed.
  - Install and secure all safety guards, doors and covers before starting
  - Bystanders should leave the immediate area before connecting the drive from the tractor.

## **Running/Operating Checks**

- Always keep the PTO output from the tractor at 540 RPM when running machinery.

## **Post-Use Regular Checks**

- Check blades, belts and wearing parts. Be sure they are not damaged and blades swing freely in their mount. Repair or replace as required.
  - Clean machinery and check for/clear any entangled material which may have got stuck around any rotating parts.

## Component Identification

1. Frame
2. Stand Leg
3. 3-Point Linkage
4. Gearbox
5. PTO Shaft Shields
6. Protection Flaps
7. Sliding Tubes
8. Rear Roller
9. Belt Drive/Belt Gaurd
10. Skid

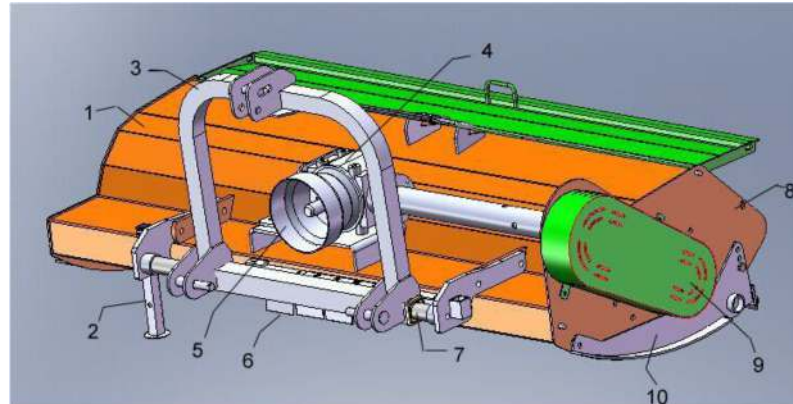

Specifications	GK160	GK180	GK200	GK200
Structure Weight	890 lbs	930 lbs	970 lbs	1010 lbs
Working Width	5'	5'6"	6'3"	6'9"
Flail Type	3 1/2"	3 1/2"	3 1/2"	3 1/2"
# of Hammers	20	24	28	28
Tractor HP	25-35 hp	40-50 hp	55-70 hp	55-70 hp

## Installation & Set Up

**Safety:** Ensure tractor and machine is stopped and the key is out of the ignition before set up/maintenance.

**Safety:** Make sure the PTO drive isn't connected at any point until instructed to do so.

### ***Attaching The Mower***

Start by finding a flat piece of ground. Lower the three point linkage on your tractor to its lowest position and attach the mower to the tractor using the three point linkage pins and lynch pins.

Attach the hydraulic connections [see section on hydraulic fitting & operation]. Then, with the rear roller on the mower on the ground, adjust the length of the top link arm and use the tractor hydraulics to ensure the skids at the side of the flail mower are parallel with the ground when horizontal.

By hand, rotate the blade rotor so that a row of blades hang vertically towards the ground to give an idea of the cutting height. Check the clearance between the bottom of the blades and the ground, this should be at least 2 inches.

The cutting height can be set for longer grass by simply raising the hydraulic lift arms on your tractor or/and by adjusting the rear roller and skids on the machine to increase or decrease the blade clearance as required [ see section on adjusting the cutting height].

The working speed of the machine should always be at a walking pace, depending on the working conditions. Overgrown grass and weeds should be cut at a much slower pace for the best cut and to avoid any damage to the mower.

Check your PTO's shaft's grease points and apply grease if needed. Then attach the PTO shaft and ensure the locking pin is secured on both the tractor and mower. Attach the chain to a secure point on the tractor/implement

### ***Pre-Mowing Checklist***

Before starting the machine, always check and adjust the following:

- Hydraulics and fitted and operated correctly
- Set correct cutting height
- Tension of the belt drive
- Oil Level of the gearbox
- Lubrication/Grease Points
- Tighten all bolts, nuts and screws.
- All protective guards are in place and storage stands are removed.

## Cutting Height Adjustment

**Safety:** Ensure tractor and machine is stopped and the key is out of the ignition before set up/maintenance.

**Note:** Clearance of blades to the ground should be at least 2 inches and higher on uneven ground

Getting the cutting height right is the key to creating the best cut and finish when mowing. This needs to be adjusted to the way of the land and also the length of the grass and density of the weeds.

The cutting height can be set for longer grass by simply raising the hydraulic lift arms on your tractor or/ and by adjusting the rear roller and the skids on the machine.

### Roller Adjustment

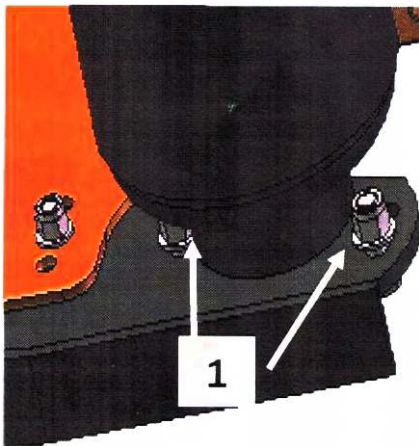

1. Remove bolt/bolts **1** on both sides of machine to adjust to desired height.
2. Adjust roller by aligning the selected holes in the roller support holes at position **2** (using the hole closest to the ground gives the highest working height).
3. Put bolt **1** into selected hole/holes **2** and re-tighten bolt/bolts **1**.

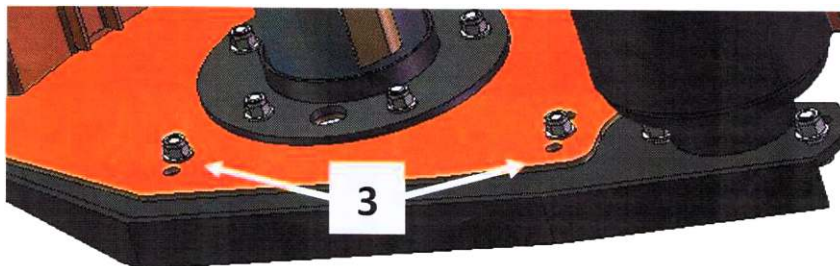

1. Remove the nuts and bolts **3** on the skids front & back of both sides of the machine
2. Move the skids up or down to the desired height with the set holes on the skids
3. Re-fit nuts and bolts **3**.

**Safety:** Ensure tractor and machine is stopped and the key is out of the ignition before set up/maintenance.

**Correct Belt Tension**

The correct belt tension is achieved when the belt can be deflected by the belt thickness about 3/8 at the centre point between the pulleys. Tension should be checked regularly.

A generic measure across machines is the belt should be able to twist a quarter turn by hand, any more and they are too loose and any less are too tight. You may run the risk of loosing drive to the mower or burning the belts permaturely

It is important for both optimal machine performance and long lasting belt life that belts are correctly tensioned at all times. Tension is correct when a force of 20 lbs exerted on the belts at their mid-point between the upper and lower pulleys deviates the belts by 15mm.

If the belts require tensioning follow the procedure stated below.

after an intial first 1 hour of work check belt tension and taper locks (indicated 1 & 2 in the photo below right) tighten if required.

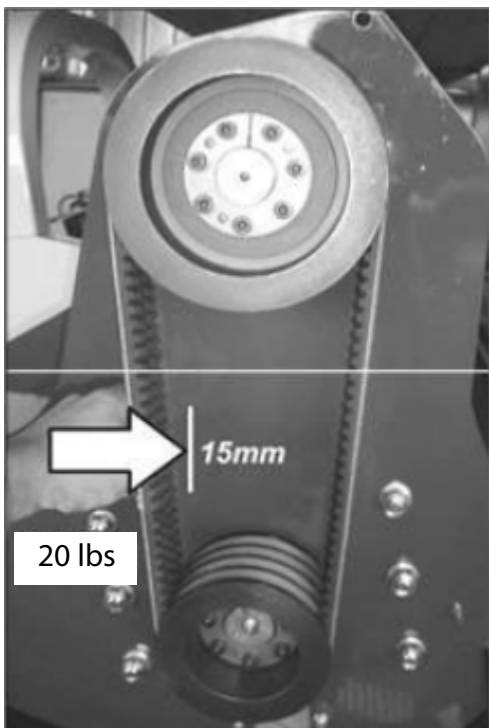

Belt Tension - 15mm deviation under 20 lbs pressure at mid-point of belt run.

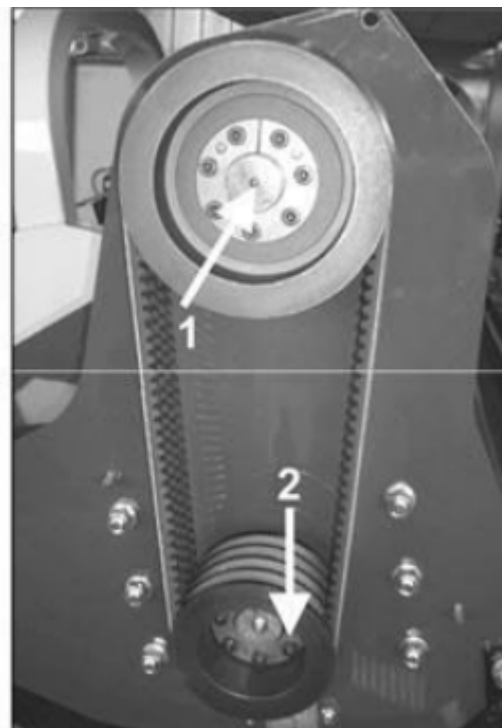

Taper Locks - Check tightness on new machines after initial 2 hours of work.

## **Operation**

Ensure that the operator is suitably qualified to use a machine of this nature and that they have fully read and understood this manual - they should be aware of all the safety aspects relating to the safe use of the machine. It is advisable that all 'first time' operators practice using the machine in a clear safe area prior to work in order to familiarise themselves with its operation.

After the first initial 1 hour of work with the new machine, nuts and bolts should be checked for tightness and the drive belts inspected and re-tensioned if required.

Prior to starting work, the area should be scanned for dangerous objects such as large rocks, wood, glass, wire etc. Hazardous objects should be removed or marked to indicate to the operator that the area should be avoided or to provide caution while working in the area.

## **Starting work**

With the machine switched off, lower it into a position approximately 4 inches above the ground, start the machine and allow it to build up to correct working speed before gently lowering it to the ground - the machine is now in its work position and forward travel can begin.

## **Forward Speed**

The forward working speed will depend on the working conditions and nature of the material being cut. Optimal speed will be in the region of 2-5 MPH.

## **Reversing & Turning**

When reversing or turning the unit the machine must always be lifted clear of the ground to avoid damage.

## **Transport**

The following must be observed at all times when transporting the machine:

- Machine must always be switched off
- Machine must be raised
- Speed must be kept to a minimum especially on bumpy roads or terrain
- Always abide with local laws and road regulations
- be aware of the machine width

## **Detaching & Storing the Machine**

- Removal of the machine should be performed on a firm and level site.
- Gently lower the machine fully to the ground
- Switch off the tractor and remove its starting key
- Remove the PTO drive shaft
- Chock the rear roller to prevent movement of the machine during the detachment procedure and whilst in storage
- Detach hydraulic hoses where applicable
- Remove the top link and both pins from the lower attachment points
- Carefully and slowly drive the tractor clear of the machine
- Clean and lubricate the machine in preparation for next use

## **Storage**

For Extended periods of storage it is advised that the machine be kept in a clean dry environment protected from the elements to avoid risk of corrosion. The machine should be thoroughly cleaned and lubricated prior to storage. At this point it is good practice to check the machine for worn or damaged components. Any parts that require replacing should be ordered and fitted at the earliest opportunity so the machine is fully prepared for the next seasons work.

## **Maintenance**

All maintenance, cleaning and repair operations must be performed with the machine firmly lowered to the ground and detached from the tractor or with the PTO disconnected, engine switched off and the key removed. For any maintenance or repairs that require underneath the machine, it should be safely raised and propped using suitable purpose designed supports capable of bearing the weight of the machine. Care should be adopted at all times when working with or under a raised machine.

### **Maintenance tasks**

The following preventive maintenance tasks should be performed at the timescales stated to both maximise efficiency and prolong the working life of the machine.

#### **After first hour of work - New machine or machine fitted with new belts**

- Check all nuts and bolts for tightness - retighten if required.

#### **After 8 Hours of work**

- Check all nuts and bolts for tightness - Retighten if required.
- Check belt tension and adjust if required - Refer to the belt section for details of adjustment.
- Check wear and condition of flails - Replace missing or damaged flails.
- Check condition of safety guards - Repair or replace if not performing correctly.
- Lubricate grease points.
- Check gearbox and half-shaft oil level - Top up if required.
- Check rotor - Remove foreign objects that may be fouling or lodged in the rotor.
- Check frame and 3-point hitch - Ensure all components are in safe working condition.

#### **After every 100 hours**

- Grease PTO driveshaft - Separate telescopic drive and apply grease to the internal shaft.

#### **After 12 Months**

- Change gearbox and half-shaft oil.

## Gearbox Lubrication

The photos show the lubrication access points for the gearbox and halfshaft. Lubricant level should be checked on a daily basis during work and topped up only if required. Checking of the lubricant level is performed by removal of the level plug on the half-shaft. The lubricant should be inline with the bottom of the plug aperture.

'Topping up' of the lubricant is performed via the filler plugs to a point where the oil starts to 'dribble' out of the level plug. REplace and tighten all plugs before using the machine. Gearbox and half-shaft lubricant should be replaced annually. The drain plug for changing the lubricant is located on the bottom of the gear box (B).

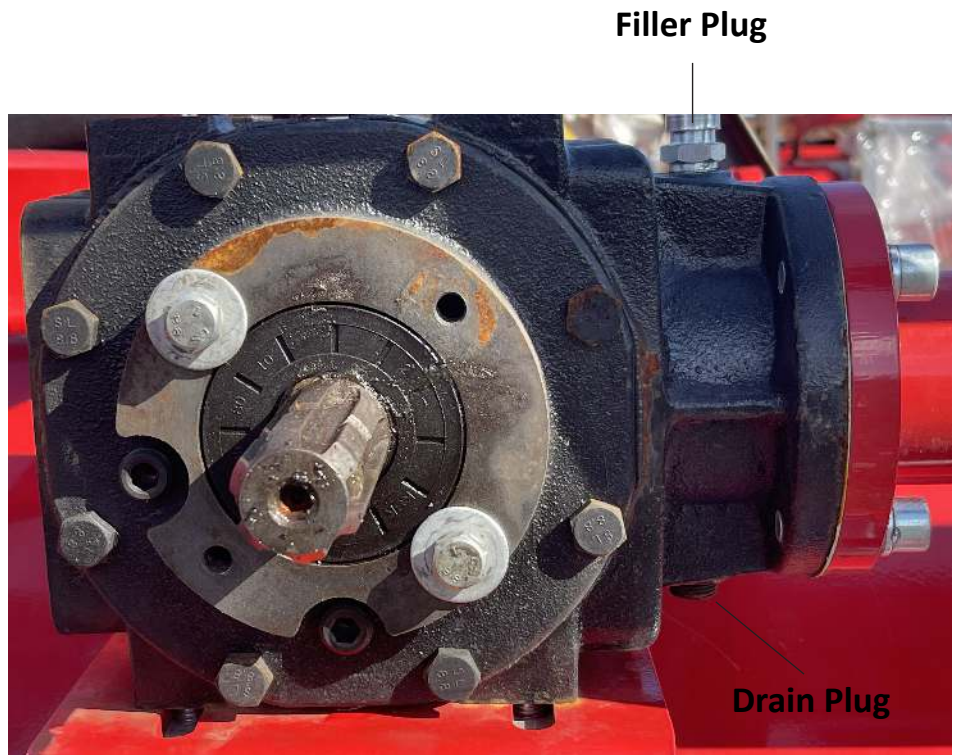

## Capacity and Lubricant Type

2.0 Litres - SAE90



## Flail Replacement

The rotor and flails should be inspected for wear or damage on a regular basis. Missing, Damaged or worn flails should be replaced immediately. When replacing a flail, the diametrically opposite flail should also be replaced at the same time in order to maintain rotor balance. The machine and tractor should be switched off and the starting key should be removed at all times when inspecting or maintaining the machine. Never work on a machine that is on and running.



## Rotor Vibration

If vibration of the rotor is experienced, the machine should be stopped and turned off. This is a sign that a flail is either missing or severely damaged. If this is the case do not use the machine until the problem has been rectified. If vibration continues, or occurs for no apparent reason, the rotor must be checked and if necessary, rebalanced before using the machine again. Always replace flails in opposing pairs.

## PTO Shaft Lubrication

The PTO shaft should be lubricated on a regular basis using lithium based grease. Each end of the shaft has two grease points; one for lubrication of the universal joint and one for lubricating the rotating fixing ring of the shaft shield. Access to the lubrication points is gained by releasing the shaft shield from its fixing ring and sliding it back along the body of the driveshaft. The procedure and lubrication frequency is illustrated below.



Shaft Shield Fixing Clasps



Insert Screwdrivers Into the Clasps



Prise Clasps Open to Release the Shield



Slide Shield Back to Reveal Universal Joint

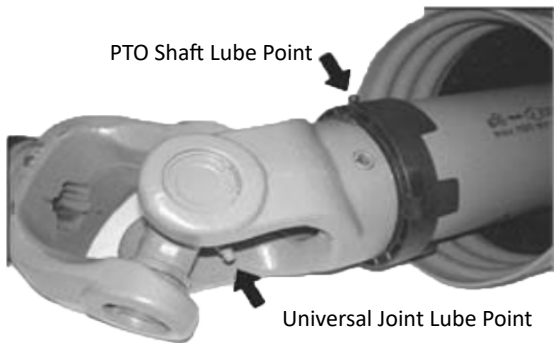

Location of Lubracation Points

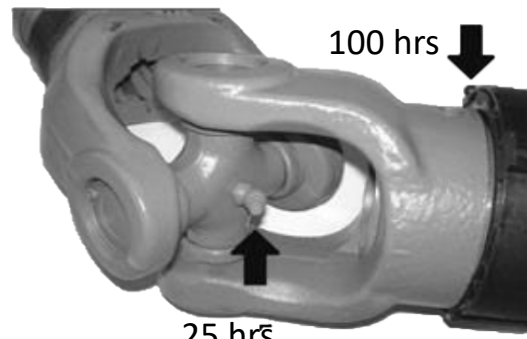

Recommended Lubricating Frequency

### Troubleshooting

PROBLEM	POSSIBLE CAUSES	REMEDIES
Irregular Cut	Worn, bent or broken flails	Replace flails
	RPM too low	Increase RPM
	Machine not level to the ground	Correct mounting on tractor
	Clogged material caused by excessive forward speed	Reduce forward speed
Noise	Loose bolts	Check and tighten bolts
	Damaged components	Repair or replace
Noisy gearbox	Lack of lubrication	Top up oil to correct level
	Worn gears	Replace worn components
	Worn bearings	Replace worn components
Vibration	Broken, worn or missing flails	Replace flails
	Rotor out of balance	Balance or replace rotor
	Worn rotor bearings	Replace rotor bearings
Excessive backlash in joints	Worn pins	Replace pins
Tight bearings	Bearings dirty or ungreased	Clean and grease
	Violent lowering down of machine	Lower machine gently
Belts overheating	Belts slipping on pulleys	Tension belts
	Flails contacting the ground	Raise cutting height
	Working speed too high	Reduce working speed

### Machine Disposal

Disposal of this machine and any of its component parts must be performed in a responsible and inoffensive manner respecting all current laws relating to this subject. Materials forming this machine that must undergo differentiated division and disposal are:

- Steel
- Mineral Oil
- Rubber
- Plastic

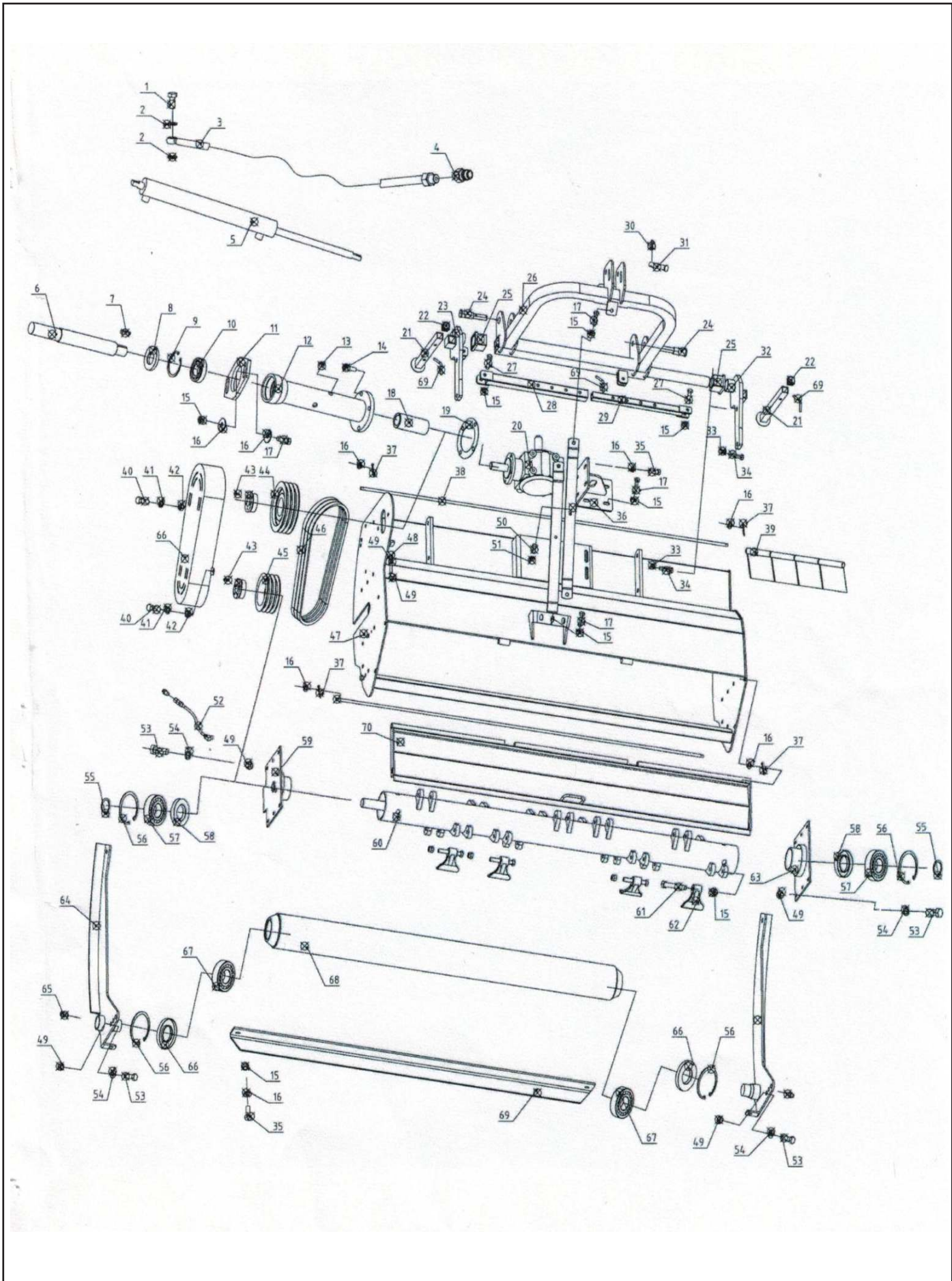

NO.	PART #	NAME & SPECIFACATION	QTY.	REMARK
1	GB3451-83	Hollow Bolt M12x1.25x25	2	
2	JB 982-77	Seal Washer 12	4	
3	BCS170.016	Oil Hose	2	
4		Quick Connect 1/2 NPT	2	
5	GK180.027	Oil Cylinder	1	
6	GK180-028	Transmission Shaft	1	
7	GB1096-03	Flat Key A 10x40	1	
8	GB13871-94	Oil Seal 40x80x10	1	
9	GB893.1-86	Circlip for Hole 80	1	
10	GB/T276-94	Bearing 6208	1	
11	GK180-105	Retaining Plate	1	
12	BCS170.020	Drive Shaft Weldment	1	
13	ZBT32001.3-87	Hex Socket Plug 3/8-19	2	
14	GB70-80	Hex Socket Screw M12x35	4	
15	GB6184-86	Locknut M12	47	
16	GB96-85	Large Washer 12	10	
17	GB5783-86	Bolt M12x40	44	
18	EF175-105	Drive Shaft Tube	1	
19		Paper Washer (EF)	1	
20	1.311.0303.00	Gearbox	1	
21	GK180-026	Support Leg	2	
22	GK180-111	Cover	2	
23	GL180-014	Support Arm L	1	
24	BCS170.104	Lifting Pin B	2	
25	GK180-112	Brush	2	
26	GK180-016	Front Lifting Braket	1	
27	GB5783-86	Bolt M12x85	2	
28	GK180-017	Inner Adjust Tube	1	

NO.	PART #	NAME & SPECIFACATION	QTY.	REMARK
29	GK180-018	Outer Adjust Tube	1	
30		Lock Pin	1	
31	IG180-104	Lifting Pin	1	
32	GK180-010	Support Arm L	1	
33	GB6184-86	Locknut M16	4	
34	GB5783-86	Bolt M16x65	4	
35	GB5783-86	Bolt M12x30	4	
36	GK180-015	Support Plate	1	
37	GB91-86	Split Pin4x25	2	
38	GK180-108	Axel for Baffle	2	
39	EF175-108	Baffle	17	
40	GB5783-86	Bolt M10x35	2	
41	GB96-85	Large Washer 10	2	
42	GB6184-86	Locknut 10	2	
43	GB70-85	Hex Screw M8x30	10	
44	BCR140.103	Driving Pulley	1	
45	BCR140.104	Driven Pulley	1	
46		V-Belt BX50	3	
47	GK180-011	Blade Axel Cover	1	
48	GB5783-86	Bolt M14x80	1	
49	GB6184-86	Locknut M14	10	
50	GB5783-86	Bolt M10x30	3	
51	GB6184-86	Locknut M10	1	
52		Grease	1	
53	Gb5783-86	Bolt M14x40	8	
54	GB96-85	Large Washer 14	10	
55	GB893.1-86	Circlip for Shaft 40	2	
56	GB893.1-86	Circlip for Hole 90	4	





## PTO Shaft Resizing

**Safety:** Ensure tractor & machine is stopped and keys are out of the ignition before carrying out any work. If you are not confident in carrying out the work, consult your local supplier or mechanic.

Most PTO driven implements are supplied with a standard size PTO shaft. As all tractors vary, this often means cutting it down to size. Always replace worn or damaged PTO shafts.

Attach the machine to the tractor without the PTO shaft, raise the linkage so the PTO shaft is level/horizontal. Measure the length between tractor PTO and the machine's shaft. If the compressed (closed) PTO shaft length exceeds the one measured here then the driveline will need to be cut.

### 1. PTO length adjustment, First remove shaft shielding

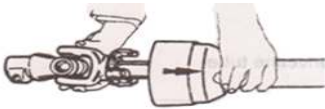

### 2. Shorten the driveline tubes to proper equal lengths



### 3. Tidy edges of the drive tube with a file and clean all fillings from the tubes



### 4. Shorten the equally long guard tubes to the same length as the driveline tubes

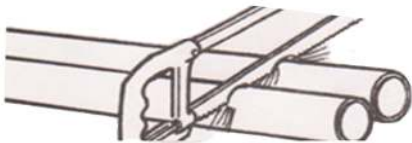

### 5. Grease the internal driveline tube



### 6. Fit the guard on the shaft

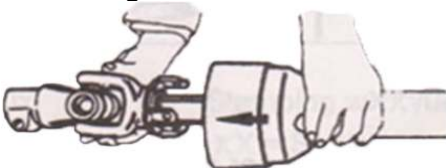

### 7. Make sure that the length allows for at least 6 inches of overlap



## Value-Leader Brand Limited Warranty

Unless otherwise stated on purchase invoice, Betstco warrants to original Purchaser that Value-Leader products are free from major defects in material under normal use and service for a period of Two (2) Years from the date the product is purchased or shipped, whichever is later. Commercial use 180 days. Use at address that is not yours, is considered commercial use. Consumable, Expendable, Wear Items (Rubber plastic parts, hydraulic hoses, belts, tires, cables, blades, tines, wedges, teeth, tiups, chains, pins, brushes, filters, etc) and cracked hydraulic pumps, bent or broken cylinder rods are not covered under this warranty. Warranty does not cover items that have been modified, damaged by abuse or usage not in accordance with design or maintenance.

Betstco obligation under this warranty is to repair or replace defective upon approval by; Betstco, 83371 Melton Rd. N, Creswell OR 97426 that Warranty Claim is valid. Product shall be returned upon request of Betstco. Transportation charges to be prepaid by user.

**Gasoline or diesel engines used to powered Value-Leader products are covered by the warranty of the appropriate engine manufacturean Purchaser must look to the engine manufacture for all issues relating to engine operation.**

***Betstco assumes no responsibility for outside labor.***

***PERMISSABLE BY APPLICABLE LAW, BETSTCO HEREBY DISCLAIMS ALL WARRANTIES OF ANY KIND, EITHER EXPRESS OR IMPLIED, INCLUDING, ANY IMPLIED WARRANTIES WITH RESPECT TO THE PRODUCT PURCHASED, WITHOUT LIMITING THE GENERALITY OF THE FOREGOING, BETSTCO HEREBY EXPRESSLY DISCLAIMS ALL LIABILITY FOR PRODUCT DEFECT OR FAILURE, CLAIMS THAT ARE DUE TO NORMAL WEAR, PRODUCT MISUSE, ABUSE, PRODUCT MODIFICATION, IMPROPER PRODUCT SELECTION, NON-COMPLIANCE WITH ANY CODES, OR MISAPPROPRIATION. BETSTCO MAKES NO WARRANTIES TO THOSE DEFINED AS "CONSUMERS" IN THE MAGNUSON-MOSS WARRANTY FEDERAL TRADE COMMISION IMPROVEMENTS ACT. THE FOREGOING EXCLUSION OF IMPLIED WARRANTIES DO NOT APPLY TO THE EXTENT PROHIBITED BY LAW. PLEASE REFER TO YOUR LOCAL LAWS FOR ANY SUCH PROHIBITIONS.***

***THERE SHALL BE NO LIABILITY FOR PRODUCT LIABILITY OR LIABILITY ON THE PART OF BETSTCO FOR ANY GENERAL SPECIAL OR CONSEQUENTIAL DAMAGES ARISING OUT OF THE SALE OR USE OF ANY PRODUCTS SOLD BY BETSTCO OR AN AGENT THEREOF, BETSTCO MAKES NO WARRANTIES, EXPRESS OR IMPLIED, (INCLUDING, BUT NOT LIMITED TO, ANY WARRANTY OF MERCHANTABILITY OR FITNESS OF THE PRODUCTS FOR ANY PURPOSE) WITH RESPECT TO THE PRODUCTS COVERED BY THIS AGREEMENT EXCEPT AS IN THIS PARAGRAPH OTHERWISE EXPRESSLY PROVIDED.***

***THIS IS THE SOLE AND ONLY WARRANTY OF VALUE-LEADER PRODUCTS, NO OTHER WARRANTY IS APPLICABLE, EITHE EXPRESSED OR IMPLIED, IN FACT BY LAW.***

This warranty shall not be interpreted to render Betstco, or any authorized agent liable for injury or damages of any kind or nature, direct, consequential, or contingent, to a person or property.

The sole and only remedy in regard to any defective product shall be the repair or replacement thereof as herein provided, Betstco, agent(s) of Betstco shall not be liable for any consequential, special, incidental or punitive damages resulting from or caused by any such defects

Betstco reserves the rights to make improvements in design or changes in specifacations at any time, without incurring any obligations to owners of the units previously sold.

WARRANTY VOID IF REGISTRATION IS NOT RECEIVED OR RECORDED ONLINE WITHIN 30 DAYS OF PURCHASE DATE OR SHIP DATE, WHICHEVER IS LATER.



est.1995

ITEM: \_\_\_\_\_ MODEL# \_\_\_\_\_ PURCHASE DATE: \_\_\_\_/\_\_\_\_/\_\_\_\_

PURCHASED FROM: \_\_\_\_\_ GIFT INV# ORDER# \_\_\_\_\_

OWNER NAME: \_\_\_\_\_ SERIAL # \_\_\_\_\_

OWNER ADDRESS: \_\_\_\_\_

CITY: \_\_\_\_\_ COUNTY: \_\_\_\_\_ ST: \_\_\_\_\_ ZIP: \_\_\_\_\_

PHONE: \_\_\_\_\_ EMAIL: \_\_\_\_\_

**ACCEPTANCE OF RESPONSIBILITY:**

I (PURCHASER) HAVE READ OPERATORS MANUAL AND LIMITED WARRANTY OR SOMEONE HAS READ/AND EXPLAINED ALL INSTRUCTIONS TO ME. I UNDERSTAND THIS WARRANTY DOES NOT COVER ANY LABOR AND THAT ALL DISPUTES WILL BE SETTLED BY BINDING ARBITRATION. BINDING ARBITRATION IS CONDUCTED BY THE BETTER BUSINESS BUREAU (BBB) LOCATED AT 4004 SW KRUSE WAY PLACE ST 375 LAKE OSWEGO OR 97035 OR THE CURRENT BBB LOCATION CLOSEST TO BETSTCO. I ACKNOWLEDGE MY LIMITED WARRANTY IS VOID IF ANY ATTEMPT TO REPAIR OR REPLACE DEFECTIVE PARTS HAS BEEN MADE BY UNAUTHORIZED PERSONNEL. I ACKNOWLEDGE RECEIPT OF MY OPERATORS MANUAL AND HAVE READ THE SAFE OPERATION SECTION. I ACKNOWLEDGE UNDERSTANDING MAINTENANCE AND SAFE OPERATION REQUIREMENTS, ITEM SPECIFICATIONS, OPERATION, CONTROLS AND STORAGE REQUIREMENTS. **I UNDERSTAND THAT IS ALONE AM RESPONSIBLE FOR PROPER MAINTENANCE, CARE AND SAFE OPERATION OF THIS VALUE-LEADER ITEM**

I (PURCHASER) AGREE THAT PERSONS NOT FAMILIAR WITH THE OPERATION OF THIS ITEM SHOULD NOT BE ALLOWED TO USE IT. CHILDREN ESPECIALLY SHOULD NOT OPERATE OR BE NEAR POWER PRODUCTS WHEN IN USE. ANYONE OPERATING VALUE-LEADER PRODUCTS SHOULD HAVE READ OPERATIONS MANUALS AND SAFETY MANUALS.

OWNERS SIGNATURE: x \_\_\_\_\_ DATE: \_\_\_\_/\_\_\_\_/\_\_\_\_

YOU MUST SIGN THIS WARRANTY AND MAIL OR FAX A COPY TO BETSTCO, 83371 MELTON RD N. #3, CRESWELL OR. IF YOU PREFER YOU MAY COMPLETE YOUR REGISTRATION ONLINE AT WWW.VALUE-LEADER.COM. THIS WARRANTY IS NOT EFFECTIVE UNLESS PURCHASER COMPLETE REGISTRATION AND WARRANTY FOR WITHIN 30 DAYS OF PURCHASE OR SHIP DATE WHICHEVER IS LATER.

NOTE: WE MAY REFUSE WARRANTY OF ANY KIND UNLESS BETSTCO, RECEIVES A COMPLETED, LEGIBLE AND SIGNED WARRANTY REGISTRATION. IT IS THE RESPONSIBILITY OF THE PURCHASER TO ASSURE THAT REGISTRATION DOCUMENT IS RECEIVED BY BETSTCO.

**2 YEAR EXTENDED WARRANTY & REGISTRATION  
VALUE LEADER IMPLEMENTS  
BRANDED PRODUCTS  
2 YEAR EXTENDED WARRANTY**

2 Year Extended Warranty amends to original Recorded Warranty Registration the time period of described coverage. Extended Warranty does not apply to consumable and Expendable Item as described in Product Warranty Registration.

This amendment does not affect any other part of recorded Warranty Registration or policy.

No one is authorized to alter, modify, or enlarge this Amendment to original recorded Warranty Registration

**EXTENDED REGISTRATION & PAYMENT MUST BE RECEIVED  
WITHIN 30 DAYS OF PURCHASE DATE**

*EXTENDED WARRANTY REGISTRATION*

PRODUCT & MODEL # \_\_\_\_\_

SERIAL # \_\_\_\_\_

OWNER NAME : \_\_\_\_\_

BETSTCO INVOICE # \_\_\_\_\_

**ACCEPTANCE OF RESPONSIBILITY:**

I (PURCHASER) HAVE READ AND UNDERSTAND THE EXTENDED WARRANTY OR SOMEONE HAS READ AND EXPLAINED ALL THE ABOVE TO ME. I UNDERSTAND THIS EXTENDED WARRANTY DOES NOT COVER ANY LABOR. I HAVE FILED MY ORIGINAL WARRANTY REGISTRATION AND FULLY UNDERSTAND MY REQUIREMENTS. ***I UNDERSTAND THAT I ALONE AM RESPONSIBLE FOR PROPER MAINTENANCE, CARE AND SAFE OPERATION OF THIS TRACTOR IMPLEMENT.***

OWNERS SIGNATURE: x \_\_\_\_\_ DATE: \_\_\_\_/\_\_\_\_/\_\_\_\_

FAX TO 1-541-895-2756

YOU MUST SIGN THIS WARRANTY AND MAIL OR FAX A COPY TO BETSTCO, 83371 MELTON RD N. #3, CRESWELL OR. IF YOU PREFER YOU MAY COMPLETE YOUR REGISTRATION ONLINE AT [WWW.VALUE-LEADER.COM](http://WWW.VALUE-LEADER.COM). THIS WARRANTY IS NOT EFFECTIVE UNLESS PURCHASER COMPLETE REGISTRATION AND WARRANTY FOR WITHIN 30 DAYS OF PURCHASE OR SHIP DATE WHICHEVER IS LATER.

NOTE: WE MAY REFUSE WARRANTY OF ANY KIND UNLESS BETSTCO, RECEIVES A COMPLETED, LEGIBLE AND SIGNED WARRANTY REGISTRATION. IT IS THE RESPONSIBILITY OF THE PURCHASER TO ASSURE THAT REGISTRATION DOCUMENT IS RECIEVED BY BETSTCO.