

# IGN TILLER SERIES



# FHM

**FARMER-HELPER  
MACHINERY COMPANY**



## OPERATION & PARTS MANUAL

*Please read these instructions before using. Always grease all fittings and be sure to always check and fill with oil before operating! Retain this manual for future use.*

# BETSTCO

RUGGED LABOR SAVING EQUIPMENT SINCE 1995

[www.Betstco.com](http://www.Betstco.com)

541-895-3083 M-F 7am-4pm PST

83371 Melton Rd, Creswell OR 97426



# ASSEMBLY INSTRUCTION



IGN Series Assembly Instructions

## Step # 0: Removing Unit from Shipping Frame

Tools Needed



Angle Grinder or Metal cutting tool



IGN Series Assembly Instructions

## Step # 1: Unhook machine from crate

Tools Needed

No Tools required

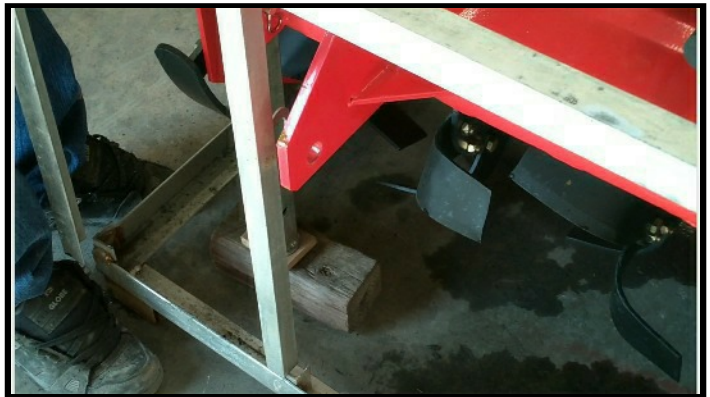

IGN Series Assembly Instructions

## Step # 2: Install lower lift pins

Tools Needed



34mm wrench or socket



IGN Series Assembly Instructions

## Step # 2: Install lower lift pins

Parts Needed



Lower lift pins

# ASSEMBLY INSTRUCTION



**BETSTCO**

IGN Series Assembly Instructions

Step # 3: Install uprights

Tools Needed



24mm wrench and socket

**BETSTCO**

IGN Series Assembly Instructions

Step # 3: Install uprights

Parts Needed



Uprights



# ASSEMBLY INSTRUCTION



**BETSTCO**

IGN Series Assembly Instructions

**Step # 4: Install tail gate adjustment**

**Tools Needed**



16mm wrench and 17mm socket

**BETSTCO**

IGN Series Assembly Instructions

**Step # 4: Install tail gate adjustment**

**Parts Needed**



16mm wrench and 17mm socket



# ASSEMBLY INSTRUCTION



**BETSTCO**

**IGN Series Assembly Instructions**

**Step # 5: Fill side case with oil**

**Tools Needed**



22mm wrench and 88-90 weight gear oil



# ASSEMBLY INSTRUCTION



## IGN Series Assembly Instructions

### Step # 6: Fill gearbox with oil

#### Tools Needed



19mm wrench and 88-90 weight gear oil

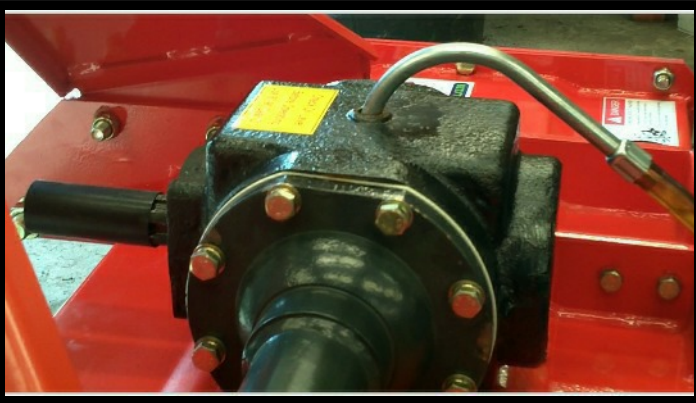
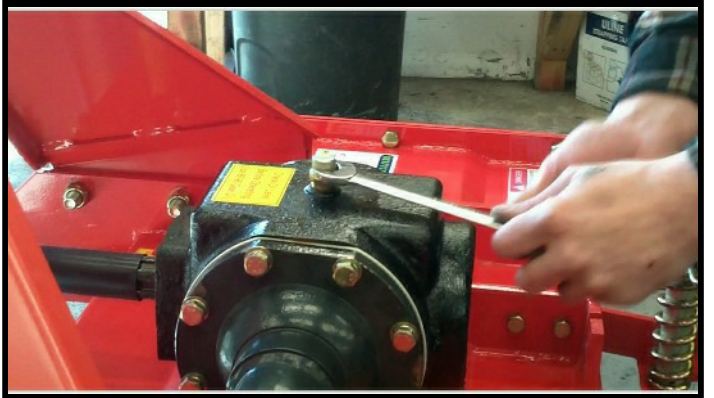

## IGN Series Assembly Instructions

### Step # 7: Lube PTO Shaft

#### Tools Needed



Grease gun



## ASSEMBLY INSTRUCTION



For any troubleshooting questions or assistance please  
Contact our support desk at (541-895-3083)

## **Adjusting PTO Driveline Slip Clutch**

### ***SLIP CLUTCH IS NOT FACTORY SET***

### **FAILURE TO ADJUST MAY RESULT IN DAMAGE TO TINES, TILLER, TRACTOR, DRIVELINE OR CLUTCH.**

There are many aspects which control the needed spring tension for the slip clutch to work properly. The steps below will describe the basic adjustments of the slip clutch. This is a trial and error setup process. You may find that the tension adjustment may need to be changed each time you use your tiller based on the changing soil conditions, tractor being used, ambient temperature, and existing wear of the clutch parts or tiller tines.

WITH TRACTOR OFF AND THE KEY IN YOUR POCKET:

-Loosen all 8 bolts & nuts on the clutch until the springs are free.

-Make sure the clutch slips.

-Tighten all 8 nuts until the nut begins to push the springs up against the flange, try first by hand, if a tool is required, do it slowly so you can observe when the springs push against the flange.

### ***OVERTIGHTENING MAY CAUSE DAMAGE TO TINES, TILLER, TRACTOR, DRIVELINE OR CLUTCH.***

-Now go test your tiller, at normal operating RPM, for no more than 6' of traveled distance with the tines in the ground tilling. If you see smoke coming from the clutch or hear a loud noise from the clutch before you finish traveling 6', STOP, the clutch is slipping.

-If it doesn't slip in the ground and you are tilling, then you are done. To be sure, check the slip clutch housing temperature. If it is hot then the clutch is slipping. Be sure to observe the clutch as often for smoke, noise and temperature.

-If it was slipping, allow it to **COOL** before adjusting and attempting to till again. If you adjust before allowing it to cool, you could terminally damage any of the moving parts of the clutch, tiller or tractor, as this may cause it to be overtightened.

-After it has cooled, tighten the nuts 1/4 turn. Then test tiller again as noted above.

***OVERTIGHTENING MAY CAUSE DAMAGE TO TINES, TILLER, TRACTOR, DRIVELINE OR CLUTCH.***

-Repeat these steps until you are comfortable that the slip clutch is not slipping under the normal operation of your tractor and the conditions in which you will be tilling.

There are many factors that may cause a need for you to adjust the clutch during operations in any given day, including soil conditions and ambient air temperature. You should check the slip clutch on a regular basis for smoke, noise and build up of heat. Failure to do this may result in terminal failure of the clutch, tiller, or tractor.

***OVERTIGHTENING MAY CAUSE DAMAGE TO TINES, TILLER, TRACTOR, DRIVELINE OR CLUTCH.***

**Always check the slip clutch adjustment before tilling on a different day, in different soil, with a different tractor, or a change in temperature.**

# Contents

<b>Chapter I Brief introduction on the structure and their adjustment.....</b>	<b>9</b>
2.1 Universal Driveshaft (Service per Maintenance Schedule).....	9
The universal driveshaft consists of universal joint head, universal joint head for male shaft, the universal joint head for female shaft and joint cross. There are rings on the both ends of joint cross to avoid the movement of joint cross, and there is also a grease zerk on the joint cross and the n.....	9
2.2 Headstock Frame.....	9
2.3 Central gearbox (Service per Maintenance Schedule).....	9
2.4 Side gearbox (Adjust per Maintenance Schedule).....	9
<b>2.5 Right side plate.....</b>	<b>10</b>
2.6 Housing Cover (Check Tine Wear) .....	10
2.7 Cultivator shaft.....	10
2.8 Trailing bar.....	10
<b>Chapter Methods of operating.....</b>	<b>11</b>
3.1 Installation of headstock frame with the main body.....	11
3.2 The methods of blade mounting.....	12
3.3 Connecting with the three-point linkage of tractor.....	12
3.4 Adjustment before working.....	12
3.6 Starting of the tiller.....	13
3.7 Selecting of forward speed.....	13
3.8 Operating of headstock.....	13
<b>Chapter IV Maintenance .....</b>	<b>14</b>
<b>To ensure that the tiller works properly, has higher efficiency and prolonging the service life, it is important that maintenance must be done properly.....</b>	<b>14</b>
4.1 Daily maintenance (after 10 hours operating).....	14
4.2 Season maintenance (after one season operating).....	14
7. Check the blade holder, replace or repair them if necessary.....	14
8. Repair the cover and the trailing bar as necessary.....	14
4.4 Lubrication sites (checked at the daily maintenance) see table 1.....	15
4.5 Storage.....	15

## **Chapter I Brief introduction on the structure and their adjustment**

These rotary tillers are tillage equipment by means of the compound motion both of the rotation of the tractor going forward. It consists of universal driveshaft, headstock frame, gearbox, side chain ox (gearbox) are transmission sets. Blade and blade shaft are working parts. Headstock, the cover and trailing bar and sets assistant.

### **2.1 Universal Driveshaft (Service per Maintenance Schedule)**

The universal driveshaft consists of universal joint head, universal joint head for male shaft, the universal joint head for female shaft and joint cross. There are rings on the both ends of joint cross to avoid the movement of joint cross, and there is also a grease zerk on the joint cross and the needle bearing must be lubricated by you injecting grease into it frequently. The universal joint head for male shaft and the universal joint head for female shaft are sliding joint and it can be pulled back and forth freely when the rotary tiller rises or falls. It must be noted that the interval between socket and shaft is in the shortest situation but the socket and the shaft can not contact each other during operating, and if the interval between the socket and the shaft is in the biggest situation, the overlap of socket and shaft must be longer or equal 1/2 length of the shaft. It is suggested that you keep the shaft greased.

### **2.2 Headstock Frame**

The upper hitch point on the headstock must be connected with the top control link of the tractor and the lower coupling pin of headstock must be connected to the lower lift arms links of the tractor to make the rotary tiller stable on the three-point hitch linkage.

### **2.3 Central gearbox (Service per Maintenance Schedule)**

The central gearbox assembly consists of gearbox, front cap, rear cap, first shaft, second shaft and a helical bevel gear pair that transmits the power to side gear box, etc. There is an oil hole for adding oil on the top of the gearbox. There is a stopper for draining oil at the bottom of the gearbox. The helical bevel gear is splined on the shaft. The gears are tightened with elastic collar, washer and locknut to prevent axial moving.

In using, the bearing clearance and the gear backlash will be changed because of wearing of bearings and gears, so you must adjust them (if necessary). Adjustment of helical bevel gear backlash: A proper backlash is the one of the condition for working normally. If the backlash is too small, result in the gear wearing rapidly or even chipping one another. If the backlash is too large, result in the gear making strong collision, excess wear and loud noise.

#### **Precaution:**

Helical bevel gear backlash must be adjusted after the clearance of bearing on the first shaft has been adjusted. For retaining the clearance of bearing which has been adjusted, for pinion, the total thickness of adjusted shims of the front and behind bearing seat on the first shaft must keep up. For example, when moving the pinion forward, the decrease--the adjusted shims of the hind-bearing seat on the first shaft must added to the front bearing seat on the first shaft, vice versa. For large helical bevel gear, when moving it rightward, you must decrease the shims of the bearing seat of the large bevel gear. In general, just move the pinion forward when you do it. For adjustment of the bearing axial clearance on the second shaft when the axial displacement has occurred on the second shaft, you must adjust it in the following steps: First, loosen washer and screw down the locknut, then adjust the displacement of the bearing on the second shaft until there was no distinct axial movement and easy to rotate the shaft. Finally, lock the jam nut with the washer. This prevents the bearing from loosening.

### **2.4 Side gearbox (Adjust per Maintenance Schedule)**

The side chain box consists of chain box, two chain wheels, chain, chain tension units, second shaft and shaft left side plate assy. Adjustment of the chain: loosen and screw down the adjustable screw to adjust the tension of the chain, keep the right tension. In general, it can be pressed down 10mm at another side of chain. The side gearbox consists of side gearbox, three shaft and left side plate assembly.

## **2.5 Right side plate**

The right side plate assembly consists of right side plate, right head of cultivator shaft, right side bearing and bearing seat.

## **2.6 Housing Cover (Check Tine Wear)**

A specific purpose of the cover is warding off clods, safeguarding the driver and farther break down the clods. The rotary tiller is designed with a proper gap between the blade edge and the cover. As the tines blades wear, the gap will become too large and the clods would be thrown to the front of the cultivator shaft, so that it will be cultivated once more, therefore the power of the tractor will be wasted. It is recommend that when the gap from the tine tip end is greater than 45mm that the worn tines be replaced.

## **2.7 Cultivator shaft**

The cultivator shaft assembly consists of cultivator shaft, blade disc and blade.

## **2.8 Trailing bar**

The function of the trailing bar is to further break the clods and flatten the cultivated soil as the soil contacts the cover. You can obtain different effect of land surface by adjusting the height of the trailing bar. In general, if the soil is dry, set lower, if the soil is wet, to set higher. When you remove the weed on the cultivator shaft, assemble the blades, long-distance transport; you can set the bar at the highest.

## Chapter Methods of operating

### ***3.1 Installation of headstock frame with the main body***

Before being put in the crate, the headstock frame is parted with the main body. Simply attach it on the main body with the bolts provided. Pay attention to fitting the spring washers on the bolts, and fastening them firmly.



### **3.2 The methods of blade mounting**

Avoid mounting the blades in reverse and making the back of the blades enter into soil. The tines will be damaged when mounted in reverse. The left-bent blades and the right-bent blades work in a stagger state on the blade shaft. Only a blade enters into soil at the same time. This arrangement is suitable for flat plowing. So the blade shaft operates stably; the surface of the plowed field is smooth.

### **3.3 Connecting with the three-point linkage of tractor**

The connecting the rotary tiller to the tractor three-point hitch.

1. Align with the center of headstock by reversing the tractor, raise the link arm to appropriate height, reverse the tractor to make the link arm of tractor joint with the left and right pin of rotary tiller.
2. First install the left lower linkage arm, then install right lower linkage arm, (because the leveling lift rod has screw that can be adjusted length.) finally insert the pins.
3. Install the upper linkage arm, and then insert the pin.
4. See Drive line and drive line slip clutch manual for proper connections and adjustment of the Driveline and clutch.

### **3.4 Adjustment before working**

#### **1. Adjustment of horizontal level**

Put it down to make the blade tips near the ground, observe if the height between the right and left blade tips and the ground is the same or not. If not, it is necessary that the right linkage arm of tractor be adjusted to level off the blade shaft, which ensures the uniformity of working depth.

#### **2. Adjustment of longitudinal level**

Lower the tiller to tillage depth desired, observe that driveshaft and PTO shaft are level or not. If the angle of driveshaft is too great (greater than 30 degrees), adjust the control link to make it as level as you can.

#### **3. Adjustment of rising height**

The tiller should not operate with driveshaft angle that is above 30°. If it is required that tiller is risen higher, such as when the tractor with the tiller passes through ruts and earth dyke or is driven on the road, the power driving the tiller must be turned off to prevent driveshaft damage and danger. The position of the handle of the 3-point lift control must be limited.

#### **4. Primary adjustment of working depth**

Loosening the bolt on the depth skids and adjust the position of the fixing hole used, and then reattach bolt in the hole selected. Adjusted distance is 35mm per step.

### **3.5 Cultivating route**

When working on a large piece of land, land plowing is adopted to reduce the time in tilling the land, the width of the plot selected is the whole number multiple of the working width or as near as possible, so as to decrease repeat tilling.

The flat tillage in the medium and small fields refer to in land plowing. Fig.5 In land plowing

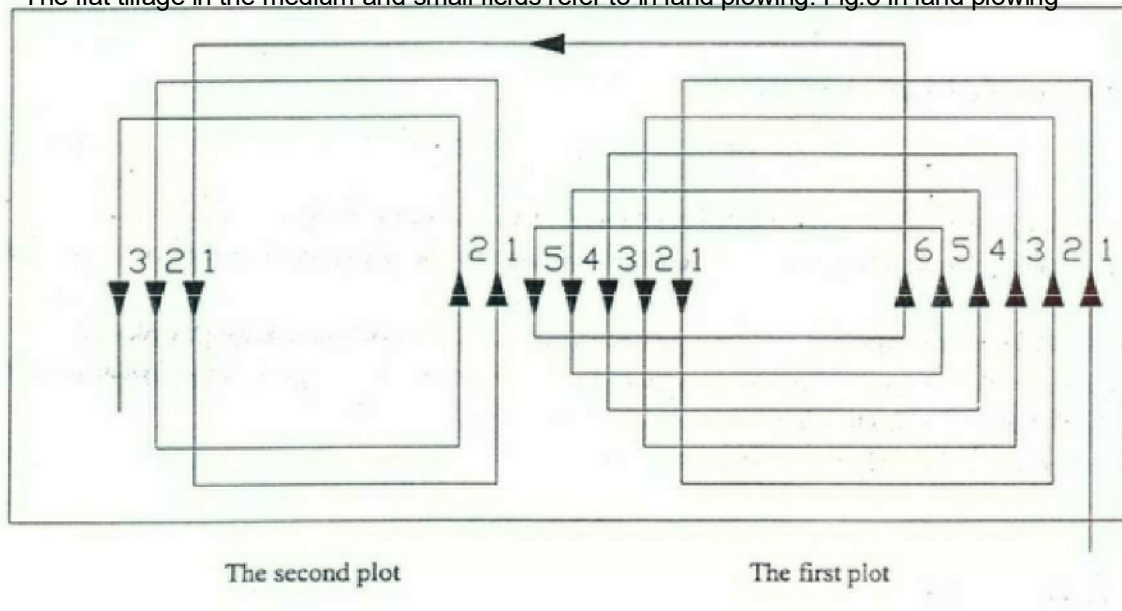

### 3.6 Starting of the tiller

First, check and fill the gear box and side box with oil as necessary. Injecting grease to the crosshead and the bearing seat of the blade shaft. Then check for the looseness of all connecting bolts and nuts, if loosening, screwing it at once. If the crack and deforming are found in the blades, they must be replaced.

Starting tractor: rise the tiller and the blade tip must be away from ground 150mm-200mm, and driveshaft coupling, then run in 1-2 minutes, gear the operating gear position and increase the fuel throttle opening, control the leveling handle to make the tiller enter into the soil gradually until the normal tillage depth at the same time.

### 3.7 Selecting of forward speed

The selecting principle of tiller forward speed: the tractor cannot overload constantly; the performance of breaking soil meet the needs of agriculture requirement, furrow bottom and the soil surface are smooth. Not only will tillage quality ensured, but also the rated power of tractor will be utilized and work efficiency will be attained.

Generally, rotary tilling directly: 2 km/h, harrowing: 5 km/h-7 km/h; if the unit draft of the soil is deeper, can select lower gear; contrarily select higher gear; when working in dry fields, select low gear; when working in wet fields adjusting forward speed as required.

### 3.8 Operating of headstock

1. Do not use the draft control of tractor during rotary tilling.
2. Using position control when doing rotary tiller work. The handle of draft control must be put in the position marked "up".
3. When the handle of position control moves forward, the tiller fall down; contrarily the tiller rise.
4. After the tiller reaching to required depth, using the position hand-wheel to block it, in favor of that the tiller falls the same depth every time.
5. The detail refer to the instruction of tractor used.

## Chapter IV Maintenance

To ensure that the tiller works properly, has higher efficiency and prolonging the service life, it is important that maintenance must be done properly.

### **4.1 Daily maintenance (after 10 hours operating)**

1. Check the lubricant oil in the gearbox and the side gear box, keep the oil level desired.
2. Check universal driveline cross, pin, grease cup on the bearing seat, inject grease into the cup.
3. Check the blades to see if the blades are damaged or their fasten bolts are loose, replace or tighten them as necessary.
4. Grease all grease points.

### **4.2 Season maintenance (after one season operating)**

Besides performing the proceeding of daily maintenance, the following must be done also:

1. Replace lubricating oil
2. Check universal driveline joints. If it is seriously worn, replace it.
3. Check the bearing in the ends of the blade shaft to see if water has entered, because of the faults in oil seals. Disassemble it to clean, replace the oil seals and inject grease.
4. Check all bearings; adjust or replace them if necessary.
5. Remove all dust and filth away from the tiller.
6. Check the blades to see if there is crack, wear and tear on them, or loss. Replaced as necessary.
7. Check the blade holder, replace or repair them if necessary.
8. Repair the cover and the trailing bar as necessary
9. The rotary tiller should be placed indoors when stored, and be raised to make the blade tips leave the ground. The blades and bare metal surfaces revealed must be smeared with oil to prevent rusting. The surface in which the paint broken off must be painted.

#### **4.4 Lubrication sites (checked at the daily maintenance) see table 1**

Table 1

Lubrication	Purpose
Oil check plug	Check the oil level of the gearbox and the side gearbox (injection should continue until oil overflows out from the oil check hole)
Ventilate screw plug	Ventilation of the side gearbox
Grease cup of the joint cross	Inject the grease into the joint cross (so that you lubricate the roller needle of the joint cross)
Grease cup of the bearing seal on the cultivator shaft	Inject the grease into the bearings and the oil seals of the cultivator shaft (lubricate the bearings and the oil seals)

#### **4.5 Storage**

The machine inside and outside shall be cleaned carefully so as to avoid corrosion.

Don't spray water on the rolling bearing if you clean the machine with high pressure sprayer.

Check and clean the drive shaft driving belt press roller, or replace them if they are not in good condition. spread oil on all parts required.

Repaint the parts rubbed and damaged for anti corrosion.

Store the machine in a dry, level area. Support the frame with planks if require.

#### **4.6 Operation After Storage**

Before the machine is started up, check the following items regularly:

Check oil level and add it if not enough.

Check and tighten all screws and nuts;

Check the blade state.

Check the air hole on the gearbox. If it is blocked, clean or open the hole with compressed air.

Don't spread oil or grease on the driving belts. If there is oil or grease on the belts, wipe the belts, in case the belt sliding and wearing occur.

## Chapter V Common breakdown and its fixing method

Breakdowns	Cause of breakdown	Removing method
Universal coupling inclined too much	Rotary tiller failed horizontal level	Adjust the horizontal level of the tiller
	One side sway chain of tractor is too short	Adjust the chain
Universal coupling injured	Direction mistaken	Re-assemble correctly
	Grease deficient	Rinse needle and inject grease sufficiently
	Angle of universal coupling is too big or is gripped	Limit the rising position and re-lock the position
	Rotary tiller fallen down the soil sharply	Fall the tiller down the soil smoothly
Noise in gearbox	The clearance between the two helical bevel gears is too large	Adjust this clearance
	Bearing injured	Replace bearing
	Tooth of gear broken	Replace gear
Noise in side gear box	Foreign matter dropped in gear box	Take foreign matter out of the gear box
	Bearing on the third shaft injured	Replace bearing
	Bearing on the middle shaft injured	Replace bearing
Trouble rotation of cultivator shaft	Gear or bearing injured or gripped	Replace gear or bearing
	There was no clearance between the two helical bevel gears	Adjust the clearance of the helical bevel gear pair
	Out of shape of left side plane	Correct side plane
	Cultivator shaft crooked or out of shape	Correct or replace cultivator shaft
	Cultivator shaft twined with grass or hold soil seriously	Clear away grass or soil
Blade slot injured	Blade run foul of stone so that it suffers too much force	Clear away the stone from the field
	Blade assembled on opposite direction so that it suffers too much force	Assemble the blades correctly
	Rotary tiller fallen down the soil sharply so that it suffers too much force	Fall the tiller down the soil smoothly
Blades crooked or broken	Blades run foul of stone	Replace the blades and clear away the stones from the field
	Doing plough when tractor turns a corner in the field	Rise the tiller and do not plough when the tractor turns a corner in the field
	Rotary tiller fallen down the hard ground	Fall the tiller down smoothly

## Chapter VI Notes for safety

1. The operators must understand the operating characteristics and notes for safe operation.
2. Check the rotary tiller overall, it cannot be used until defects are corrected.
3. The angle of drive shaft coupling is not more than 20° when it is operating, and is not more than 30° when the tractor turns a corner in the field. You must remove the drive shaft coupling when long distance transporting.
4. Do not engage the clutch suddenly when entering tiller into the soil or drop the rotary tiller into the soil. This will prevent the transmission parts of the tractor and rotary tiller from damage.
5. Do not leave tiller in the soil when the tractor turns a corner in the field.
6. Do not till when the tractor is in reverse.
7. Do not allow passengers to ride on the tractor when the rotary tiller is operating.
8. Do not get close to the rotating parts when the machine is operating.
9. The machine must be stopped and checked when hearing abnormal noise in operating.
10. The power from the PTO shaft must be cut off when checking the transmission parts, blades and gears etc. of rotary tiller. If the parts must be replaced, it is necessary to stop the engine. Do not replace the parts when the engine is operating.

1GN100/125/135/150/180/210. 02. 004

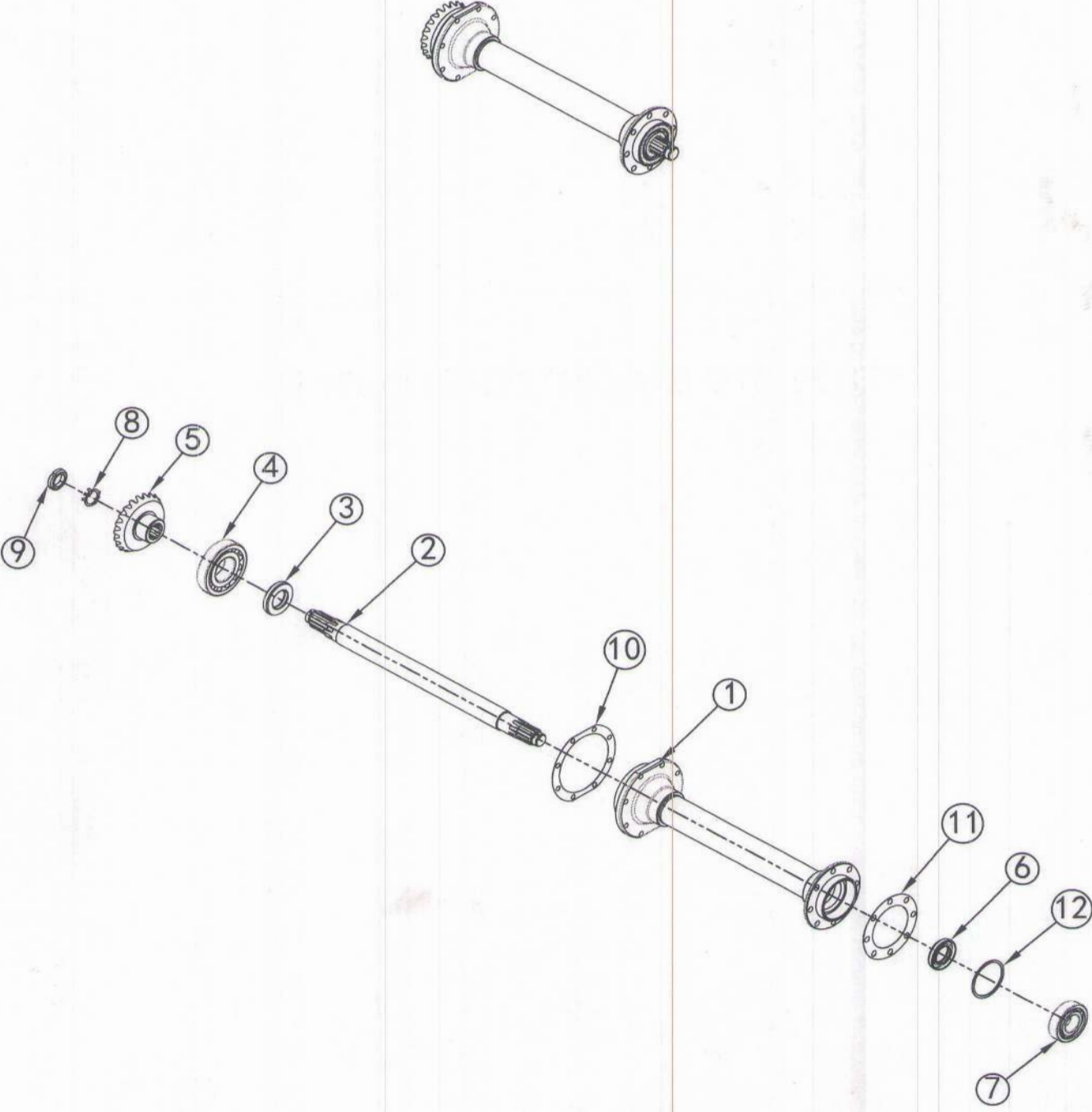

1GN135. 02. 003

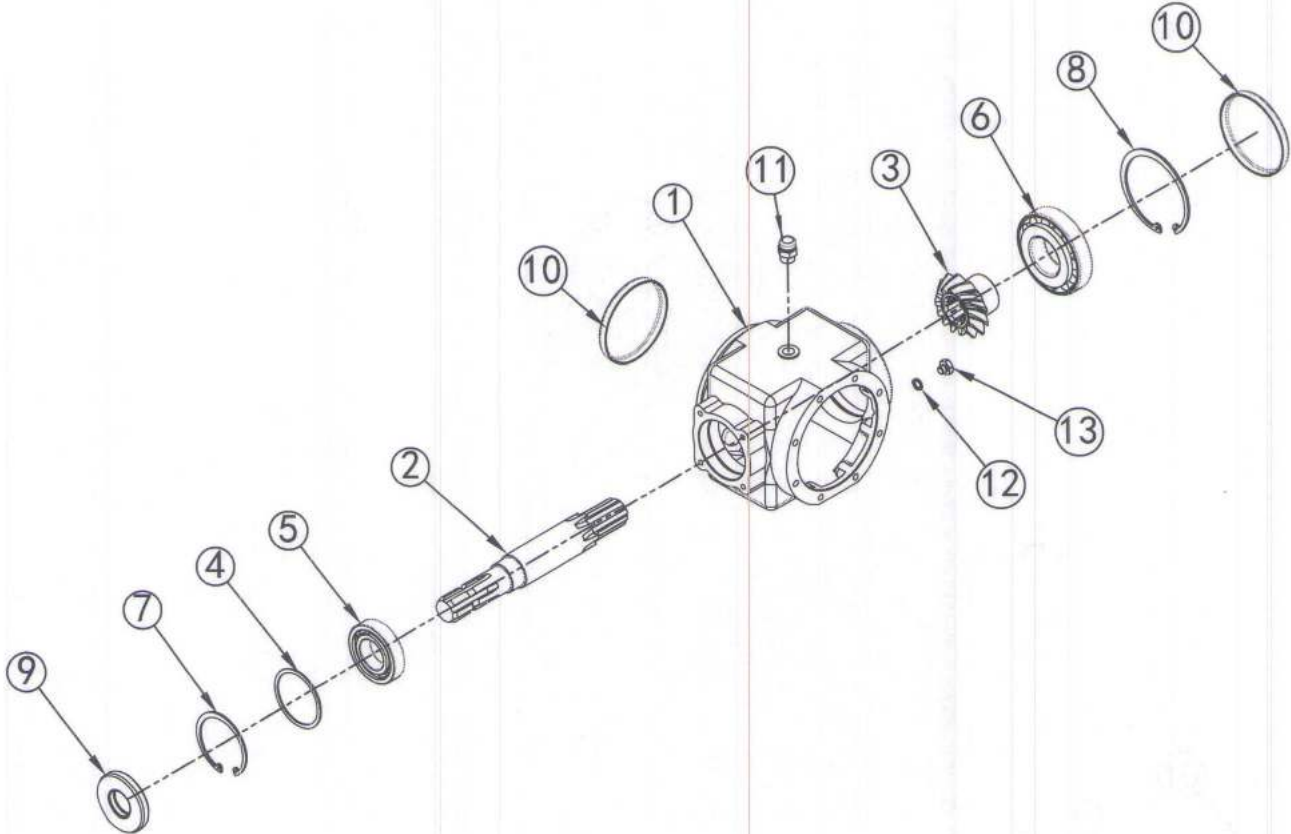
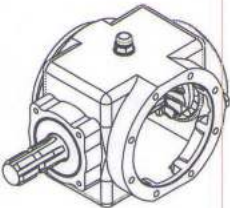

1GN100/125/135/150/180/210. 02. 002

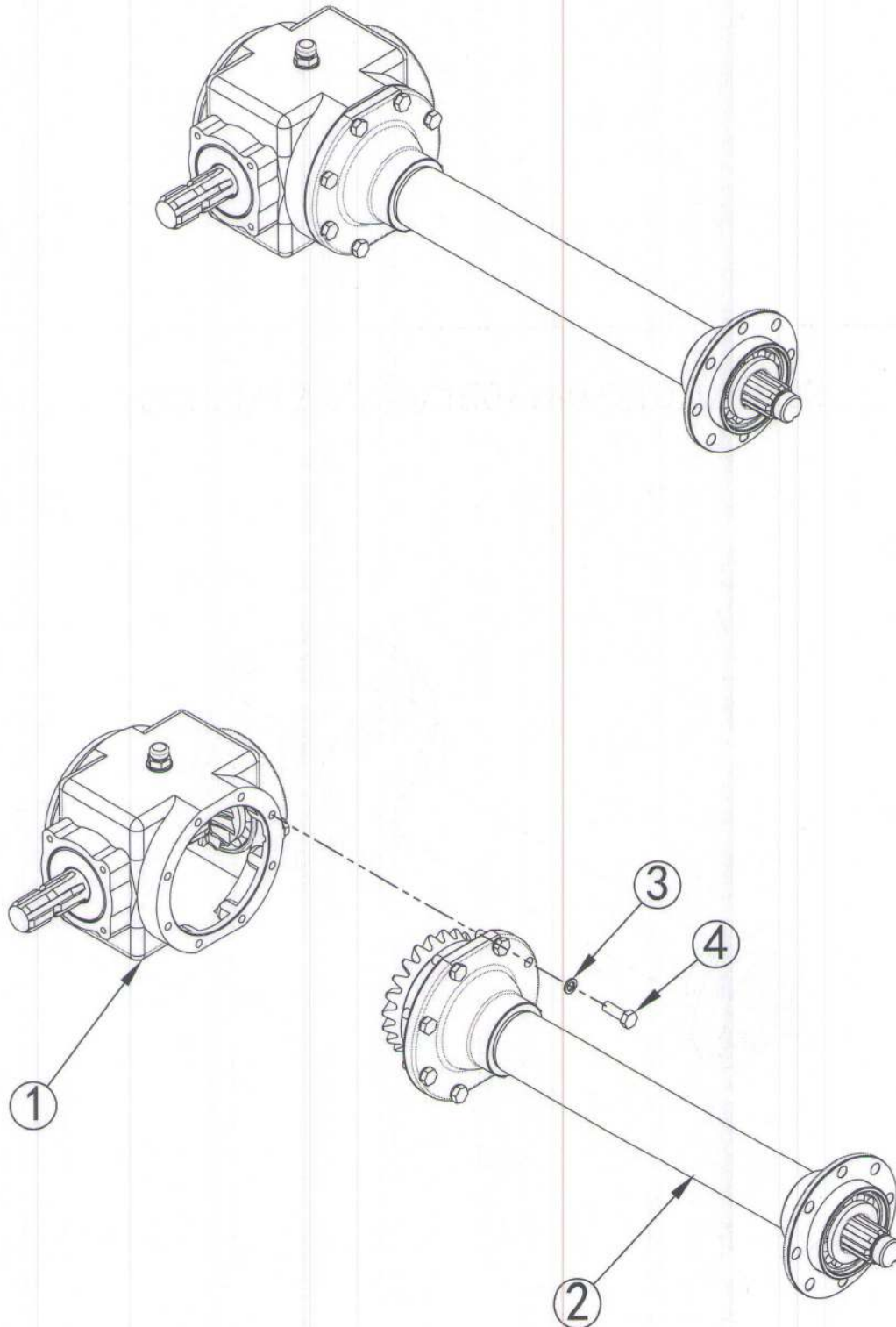

1GN100/125/135/150/180/210. 02. 001

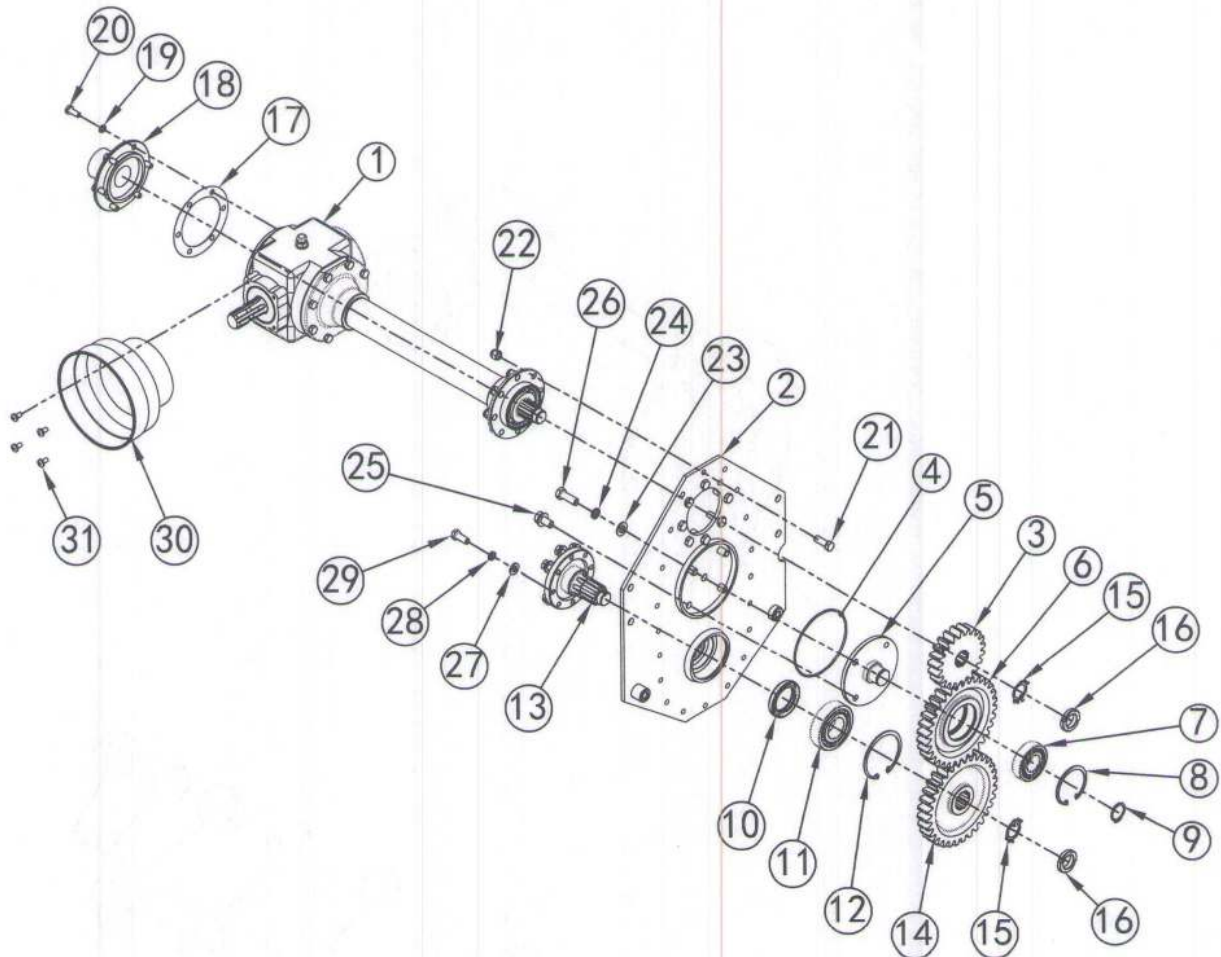
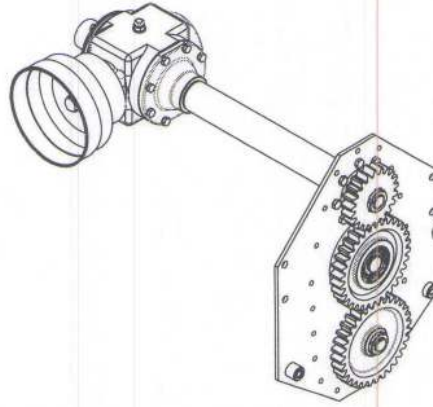

# 1GN100/125/135/150/180/210. 01. 001

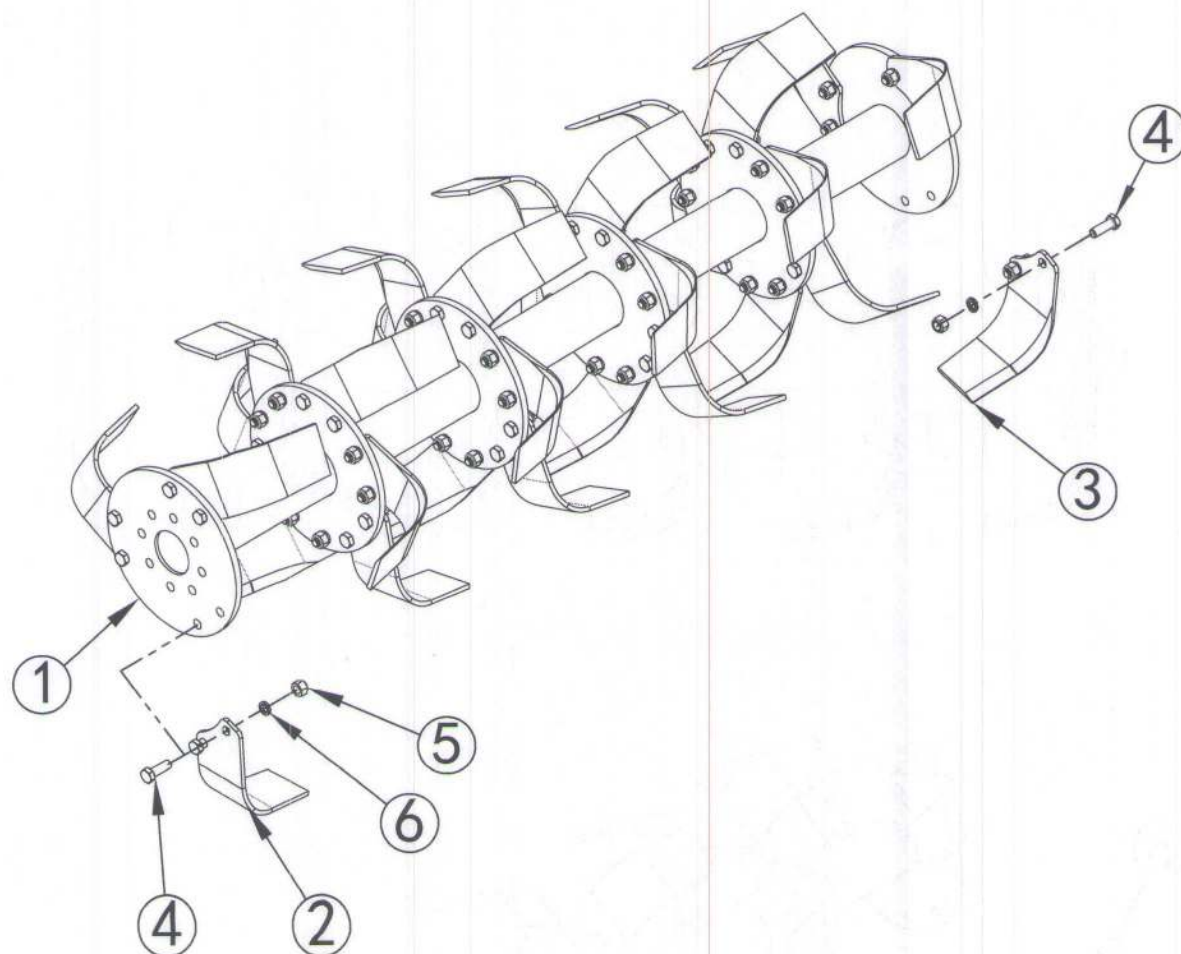
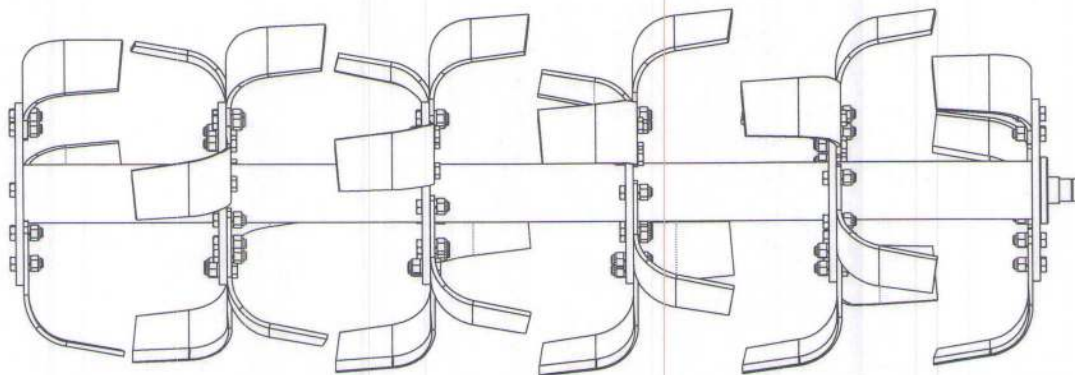

1GN100/125/135/150/180/210. 00. 003

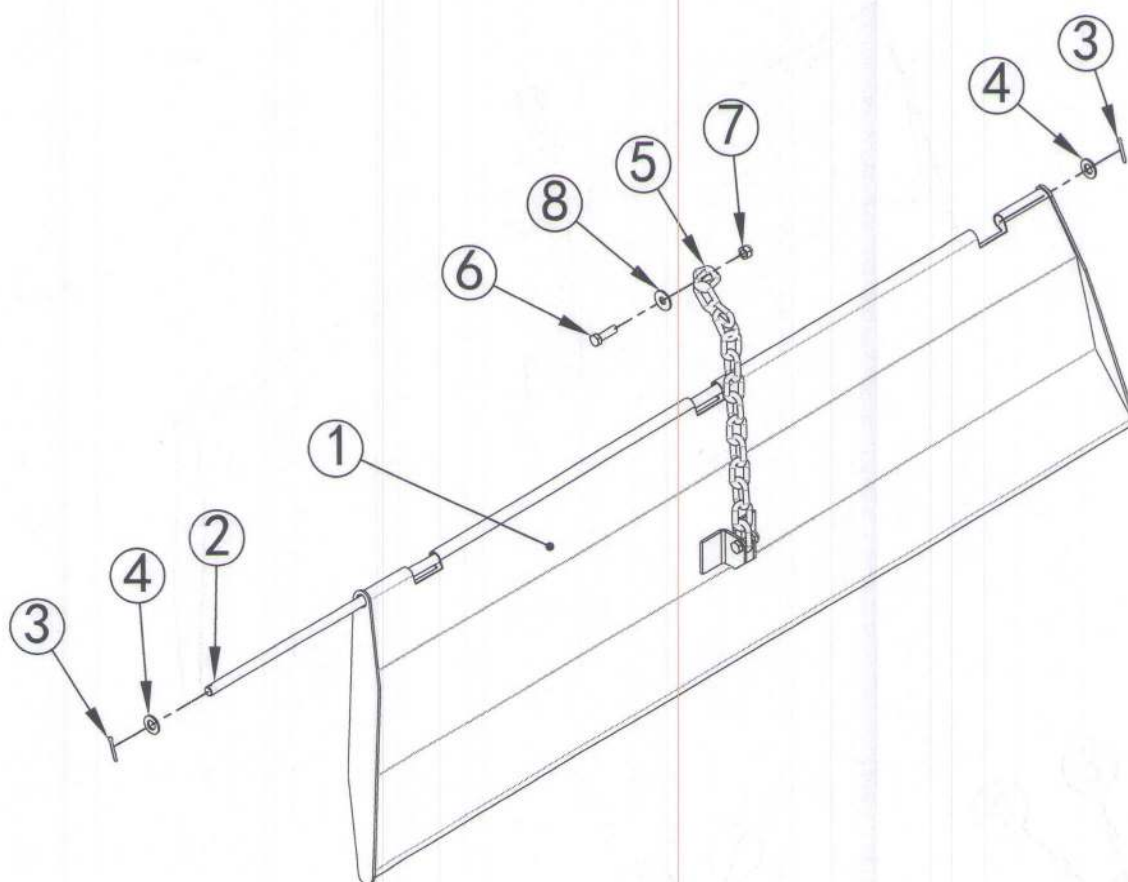
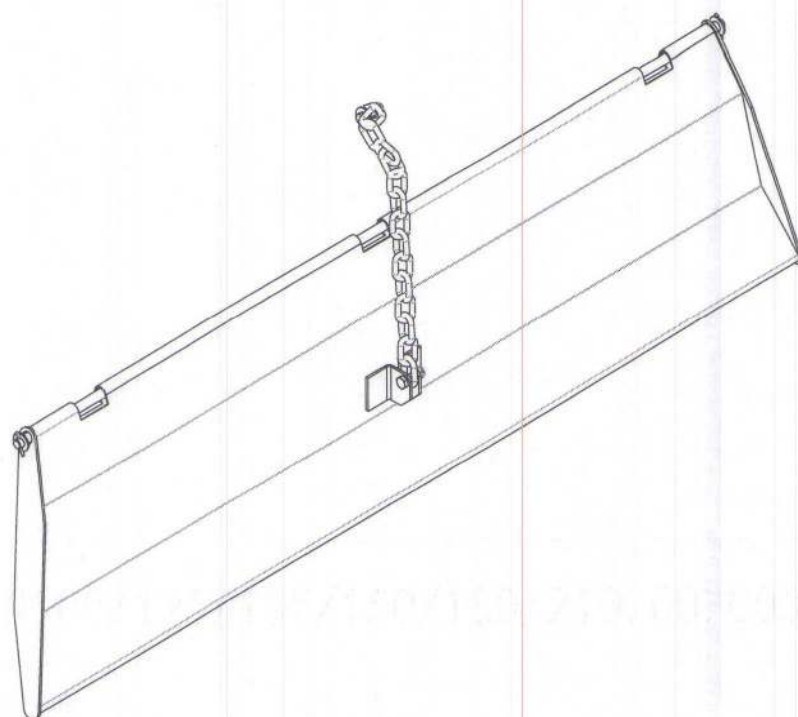

1GN135. 00. 002

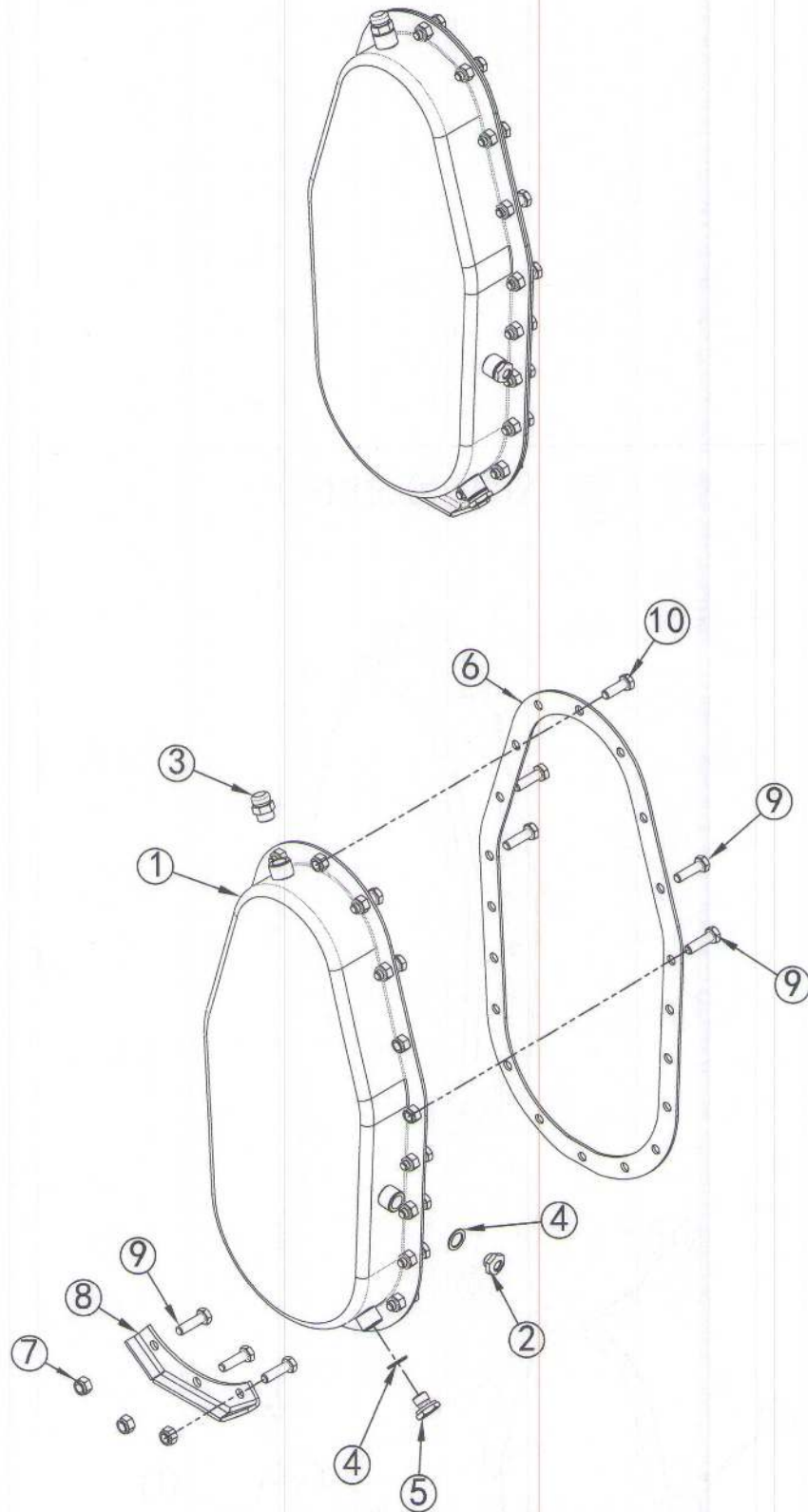

1GN100/125/135/150/180/210. 00. 001

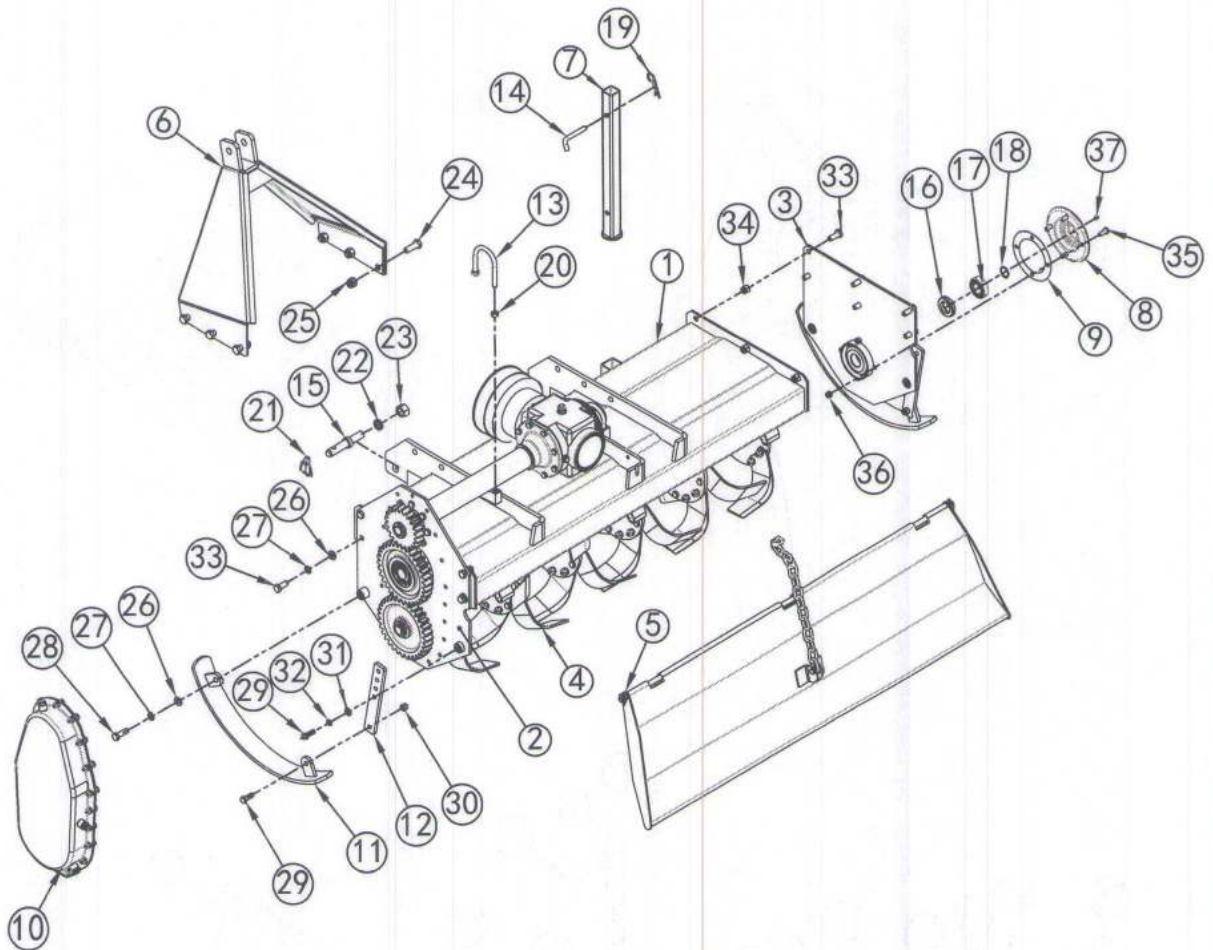
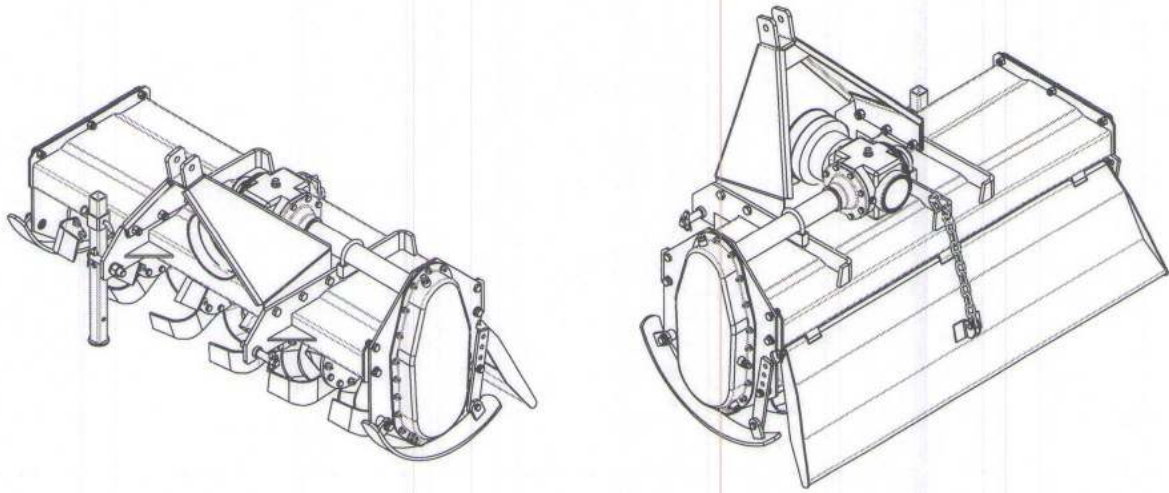

## 1GN100/125/135/150/180/210 PARTS LIST

1GN100/125/135/150/180/210.00.001

ITEM	PART No.	NAME & SPECIFICATION	NAME & SPECIFICATION	QTY.	MODEL
1	1GN100.00.013	机罩焊合件	DECK, WELDMENT	1	1GN100
	1GN125.00.013	机罩焊合件	DECK, WELDMENT	1	1GN125
	1GN135.00.013	机罩焊合件	DECK, WELDMENT	1	1GN135
	1GN150.00.013	机罩焊合件	DECK, WELDMENT	1	1GN150
	1GN180.00.013	机罩焊合件	DECK, WELDMENT	1	1GN180
	1GN210.00.013	机罩焊合件	DECK, WELDMENT	1	1GN210
2	1GN100.02.001	动力传动总成	DRIVETRAIN, ASSEMBLY	1	1GN100
	1GN125.02.001	动力传动总成	DRIVETRAIN, ASSEMBLY	1	1GN125
	1GN135.02.001	动力传动总成	DRIVETRAIN, ASSEMBLY	1	1GN135
	1GN150.02.001	动力传动总成	DRIVETRAIN, ASSEMBLY	1	1GN150
	1GN180.02.001	动力传动总成	DRIVETRAIN, ASSEMBLY	1	1GN180
	1GN210.02.001	动力传动总成	DRIVETRAIN, ASSEMBLY	1	1GN210
3	1GN135.00.012	刀轴右支撑焊合件	RIGHT SIDE BRACE,	1	
4	1GN100.01.001	刀轴总成	ROTOR, ASSEMBLY	1	1GN100
	1GN125.01.001	刀轴总成	ROTOR, ASSEMBLY	1	1GN125
	1GN135.01.001	刀轴总成	ROTOR, ASSEMBLY	1	1GN135
	1GN150.01.001	刀轴总成	ROTOR, ASSEMBLY	1	1GN150
	1GN180.01.001	刀轴总成	ROTOR, ASSEMBLY	1	1GN180
	1GN210.01.001	刀轴总成	ROTOR, ASSEMBLY	1	1GN210
5	1GN100.00.003	压板总成	DRAG SHIELD, ASSEMBLY	1	1GN100
	1GN125.00.003	压板总成	DRAG SHIELD, ASSEMBLY	1	1GN125
	1GN135.00.003	压板总成	DRAG SHIELD, ASSEMBLY	1	1GN135
	1GN150.00.003	压板总成	DRAG SHIELD, ASSEMBLY	1	1GN150
	1GN180.00.003	压板总成	DRAG SHIELD, ASSEMBLY	1	1GN180
	1GN210.00.003	压板总成	DRAG SHIELD, ASSEMBLY	1	1GN210
6	1GN135.00.014	悬挂框焊合件	HITCH FRAME, WELDMENT	1	1GN100/125/135
	1GN180.00.014	悬挂框焊合件	HITCH FRAME, WELDMENT	1	1GN150/180/210
7	1GN135.00.016	撑杆焊合件	STAND, WELDMENT	1	
8	1GNH150.025	右轴承盖焊合件	COVER, WELDMENT	1	
9	1GNH150.129	密封垫	SEAL PLATE	1	
10	1GN135.00.002	齿轮罩组合件	GEAR GUARD, ASSEMBLY	1	
11	1GN135.00.011	限深板焊合件	DEPTH GAUGE SHOE,	2	
12	1GN135.00.109	限深调节杆	ADJUSTABLE PLATE	2	
13	1GN135.00.104	U形螺栓	U-BOLT	2	
14	1GN135.00.107	弯销	PIN	1	
15	FM150.114	下悬挂销	LOWER LINK PIN	2	1GN100/125/135/150
	1GN180.00156	下悬挂销	LOWER LINK PIN	2	1GN180/210
16	GB13871.1-	密封圈FB35X62X12	SEAL FB35X62X12	1	
17	GB276-6206	轴承6206	BEARING 6206	1	
18	GB894.1-30	轴用弹性挡圈30	RETAINER RING 30	1	
19	R-PIN4	R销4	R-PIN 4	1	
20	GB889.1-M12	螺母M12	LOCK NUT M12	4	
21	LP-11x45	锁销 11x45	LINCH PIN 11x45	2	
22	GB / T 93-22×	弹性垫圈 22	LOCK WASHER 22	2	
23	GB / T 6171-M22	细牙螺母 M22x1.5	NUT M22x1.5	2	
24	GB / T 5783-M16	螺栓 M16×45	BOLT M16×45	6	
25	GB / T 889.1-	锁紧螺母 M16	LOCK NUT M16	6	
26	GB / T 97.1-14	平垫圈 14	PLAIN WASHER 14	7	
27	GB / T 93-14×	弹性垫圈 14	LOCK WASHER 14	7	
28	GB / T 5783-	螺栓 M14×45	BOLT M14×45	2	
29	GB / T 5783-M12	螺栓 M12×35	BOLT M12×35	4	
30	GB / T 889.1-	锁紧螺母 M12	LOCK NUT M12	2	
31	GB / T 97.1-12	平垫圈 12	PLAIN WASHER 12	2	
32	GB93-12	弹簧垫圈12	LOCK WASHER 12	2	

33	GB / T 5783-M14	螺栓 M14×35	BOLT M14×35	10	
34	GB / T 889. 1-	锁紧螺母 M14	LOCK NUT M14	5	
35	GB / T 5783-M10	螺栓 M10×25	BOLT M10×25	4	
36	GB / T 889. 1-	锁紧螺母 M10	LOCK NUT M10	4	
37	GB1152-M6	油杯M6	GREASE NIPPLE M6	1	

1GN135. 00. 002

ITEM	PART No.	NAME & SPECIFICATION	NAME & SPECIFICATION	QTY.	MODEL
1	1GN135. 00. 015	齿轮壳焊合件	GEAR GUARD, WELDMENT	1	
2	GB1160. 2-G3-8	圆形油标G3/8	OIL INDICATOR G3/8	1	
3	Q900B-G3-8	通气螺塞G3/8		1	
4	JB1761-16	螺塞垫16		2	
5	JB1760-M16×12	六角螺塞G3/8	HT200	1	
6	1GN135. 00. 105	密封垫	橡胶板/3	1	
7	GB889. 1-M10	螺母M10		20	
8	1GN135. 00. 108	防腐板	钢板4/Q235-A	1	
9	GB / T 5783-	螺栓 M10×35	标准件	7	
10	GB / T 5783-	螺栓 M10×30	标准件	13	

1GN100/125/135/150/180/210. 00. 003

ITEM	PART No.	NAME & SPECIFICATION	NAME & SPECIFICATION	QTY.	MODEL
1	1GN100. 00. 019	拖板焊合件	DRAG SHIELD, WELDMENT	1	1GN100
	1GN125. 00. 019	拖板焊合件	DRAG SHIELD, WELDMENT	1	1GN125
	1GN135. 00. 019	拖板焊合件	DRAG SHIELD, WELDMENT	1	1GN135
	1GN150. 00. 019	拖板焊合件	DRAG SHIELD, WELDMENT	1	1GN150
	1GN180. 00. 019	拖板焊合件	DRAG SHIELD, WELDMENT	1	1GN180
	1GN210. 00. 019	拖板焊合件	DRAG SHIELD, WELDMENT	1	1GN210
2	1GN100. 00. 186	连接杆	HINGE ROD	1	1GN100
	1GN125. 00. 187	连接杆	HINGE ROD	1	1GN125
	1GN135. 00. 188	连接杆	HINGE ROD	1	1GN135
	1GN150. 00. 189	连接杆	HINGE ROD	1	1GN150
	1GN180. 00. 190	连接杆	HINGE ROD	1	1GN180
	1GN210. 00. 191	连接杆	HINGE ROD	1	1GN210
3	GB91-4×25	开口销4×30	COTTER 4×30	2	
4	GB / T 97. 1-14	平垫圈 14	PLAIN WASHER 14	2	
5	1GN135. 00. 018	链条组合件	LINK CHAIN	1	
	1GN135. 00. 018	链条组合件	LINK CHAIN	2	1GN180/210
6	GB / T 5783-M10	螺栓 M10×35	BOLT M10×35	2	
	GB / T 5783-M10	螺栓 M10×35	BOLT M10×35	4	1GN180/210
7	GB889. 1-M10	锁紧螺母M10	LOCK NUT M10	2	
	GB889. 1-M10	锁紧螺母M10	LOCK NUT M10	4	1GN180/210
8	GB / T 96. 2-10	大垫圈 10	PLAIN WASHER 10	1	
	GB / T 96. 2-10	大垫圈 10	PLAIN WASHER 10	2	1GN180/210

1GN100/125/135/150/180/210. 01. 001

ITEM	PART No.	NAME & SPECIFICATION	NAME & SPECIFICATION	QTY.	MODEL
1	1GN100. 01. 011	刀轴焊合件	ROTOR SHAFT, WELDMENT	1	1GN100
	1GN125. 01. 011	刀轴焊合件	ROTOR SHAFT, WELDMENT	1	1GN125
	1GN135. 01. 011	刀轴焊合件	ROTOR SHAFT, WELDMENT	1	1GN135
	1GN150. 01. 011	刀轴焊合件	ROTOR SHAFT, WELDMENT	1	1GN150
	1GN180. 01. 011	刀轴焊合件	ROTOR SHAFT, WELDMENT	1	1GN180
	1GN210. 01. 011	刀轴焊合件	ROTOR SHAFT, WELDMENT	1	1GN210
2	1GN100. 01. 101	右弯刀片	BLADE, RIGHT	12	1GN100
	1GN125. 01. 101	右弯刀片	BLADE, RIGHT	15	1GN125
	1GN135. 01. 101	右弯刀片	BLADE, RIGHT	15	1GN135
	1GN150. 01. 101	右弯刀片	BLADE, RIGHT	18	1GN150
	1GN180. 01. 101	右弯刀片	BLADE, RIGHT	21	1GN180
	1GN210. 01. 101	右弯刀片	BLADE, RIGHT	24	1GN210
3	1GN100. 01. 102	左弯刀片	BLADE, LEFT	12	1GN100

	1GN125.01.102	左弯刀片	BLADE, LEFT		15	1GN125
	1GN135.01.102	左弯刀片	BLADE, LEFT		15	1GN135
	1GN150.01.102	左弯刀片	BLADE, LEFT		18	1GN150
	1GN180.01.102	左弯刀片	BLADE, LEFT		21	1GN180
	1GN210.01.102	左弯刀片	BLADE, LEFT		24	1GN210
4	GB5783-M12×35	螺栓M12×35	BOLT M12×35		48	1GN100
		螺栓M12×35	BOLT M12×35		60	1GN125
		螺栓M12×35	BOLT M12×35		60	1GN135
		螺栓M12×35	BOLT M12×35		72	1GN150
		螺栓M12×35	BOLT M12×35		84	1GN180
		螺栓M12×35	BOLT M12×35		96	1GN210
5	GB889.1-M12	锁紧螺母M12	LOCK NUT M12		48	1GN100
		锁紧螺母M12	LOCK NUT M12		60	1GN125
		锁紧螺母M12	LOCK NUT M12		60	1GN135
		锁紧螺母M12	LOCK NUT M12		72	1GN150
		锁紧螺母M12	LOCK NUT M12		84	1GN180
		锁紧螺母M12	LOCK NUT M12		96	1GN210
6	GB93-12	弹簧垫圈12	LOCK WASHER 12		48	1GN100
		弹簧垫圈12	LOCK WASHER 12		60	1GN125
		弹簧垫圈12	LOCK WASHER 12		60	1GN135
		弹簧垫圈12	LOCK WASHER 12		72	1GN150
		弹簧垫圈12	LOCK WASHER 12		84	1GN180
		弹簧垫圈12	LOCK WASHER 12		96	1GN210

1GN100/125/135/150/180/210.02.001

ITEM	PART No.	NAME & SPECIFICATION	NAME & SPECIFICATION	QTY.	MODEL
1	1GN100.02.002	传动箱总成	TRANSMISSION	1	1GN100
	1GN125.02.002	传动箱总成	TRANSMISSION	1	1GN125
	1GN135.02.002	传动箱总成	TRANSMISSION	1	1GN135
	1GN150.02.002	传动箱总成	TRANSMISSION	1	1GN150
	1GN180.02.002	传动箱总成	TRANSMISSION	1	1GN180
	1GN210.02.002	传动箱总成	TRANSMISSION	1	1GN210
2	1GN135.02.012	刀轴左支撑焊合件	LEFT SIDE BRACE, WELDMENT	1	
3	1GN135.02.110	上齿轮	GEAR, TOP	1	
4	GB3452.1-	O型橡胶密封圈	O-RING	1	
5	1GN135.02.112	中间齿轮轴	INTERMEDIATE GEAR SHAFT	1	
6	1G135.03.105	中间齿轮	INTERMEDIATE GEAR	1	
7	GB276-6307	轴承6307	BEARING 6307	1	
8	GB893.1-80	孔用弹性挡圈80	SNAP RING 80	1	
9	GB894.1-35	轴用弹性挡圈35	RETAINER RING 35	1	
10	GB13871.1-	密封圈FB55X80X12	SEAL FB55X80X12	1	
11	GB276-6309	轴承6309	BEARING 6309	1	
12	GB893.1-100	孔用弹性挡圈100	SNAP RING 100	1	
13	1G135.03.107	III轴	III-SHAFT	1	
14	1G135.03.106	下齿轮	GEAR, BOTTOM	1	
15	GB858-30	止动垫圈30	LOCK WASHER 30	2	
16	GB812-M30×1.5	圆螺母M30×1.5	ROUND NUT M30×1.5	2	
17	1GN135.02.106	密封垫	GASKET	1	
18	1GN135.02.118	短轴盖	SHAFT-CUP	1	
19	GB93-10	弹簧垫圈10	LOCK WASHER 10	6	
20	GB / T5783-M10	螺栓 M10×25	BOLT M10×25	6	
21	GB / T 5783-M12	螺栓 M12×35	BOLT M12×35	8	
22	GB / T 889. 1-	锁紧螺母 M12	LOCK NUT M12	8	
23	GB / T 97. 1-14	平垫圈 14	PLAIN WASHER 14	5	
24	GB / T 93-14×	弹性垫圈 14	LOCK WASHER 14	5	
25	GB / T 5783-	螺栓 M14×30	BOLT M14×30	2	
26	GB / T 5783-	螺栓 M14×40	BOLT M14×40	3	
27	GB / T 97. 1-12	平垫圈 12	PLAIN WASHER 12	8	
28	GB93-12	弹簧垫圈12	LOCK WASHER 12	8	

29	GB / T 5783-M12	螺栓 M12×30	BOLT M12×30	8	
30	1GN135.02.117	PTO保护罩	PTO GUARD	1	
31	GB / T 818-M8×	螺钉 M8×16	SCREW M8×16	4	

1GN100/125/135/150/180/210.02.002

ITEM	PART No.	NAME & SPECIFICATION	NAME & SPECIFICATION	QTY.	MODEL
1	1GN135.02.003	齿轮箱总成	GEAR BOX, ASSEMBLY	1	
2	1GN100.02.004	输出轴总成	OUTPUT SHAFT, ASSEMBLY	1	1GN100
	1GN125.02.004	输出轴总成	OUTPUT SHAFT, ASSEMBLY	1	1GN125
	1GN135.02.004	输出轴总成	OUTPUT SHAFT, ASSEMBLY	1	1GN135
	1GN150.02.004	输出轴总成	OUTPUT SHAFT, ASSEMBLY	1	1GN150
	1GN180.02.004	输出轴总成	OUTPUT SHAFT, ASSEMBLY	1	1GN180
	1GN210.02.004	输出轴总成	OUTPUT SHAFT, ASSEMBLY	1	1GN210
3	GB93-10	弹簧垫圈10	LOCK WASHER 10	8	
4	GB5783-M10x30	螺栓M10x30	BOLT M10x30	8	

1GN135.02.003

ITEM	PART No.	NAME & SPECIFICATION	NAME & SPECIFICATION	QTY.	MODEL
1	1GN135.02.103	齿轮箱体	HOUSING	1	
2	1GN135.02.101	I轴	I shaft	1	
3	1GN135.02.105	小锥齿轮	BEVEL PINION	1	
4	1GN135.02.135	垫圈80	GASKET 80	1	
5	GB / T 276-6208	深沟球轴承6208	BEARING 6208	1	
6	GB297-30310	滚子轴承30310	BEARING 30310	1	
7	GB893.1-80	孔用弹性挡圈80	SNAP RING IN. 80	1	
8	GB893.1-110	孔用挡圈110	SNAP RING IN. 110	1	
9	GB13871.1-	密封圈FB35X80X12	SEAL FB35X80X12	1	
10	1GN135.02.201	无孔油封110x12	COVER 110x12	2	
11	Q900B-G3-8	通气螺塞G3/8	VENTER G3/8	1	
12	JB1761-10	螺塞垫10	GASKET 10	1	
13	JB1000-AM10x1	外六角螺塞AM10x1	PLUG AM10x1	1	

1GN100/125/135/150/180/210.02.004

ITEM	PART No.	NAME & SPECIFICATION	NAME & SPECIFICATION	QTY.	MODEL
1	1GN100.02.011	轴套管焊合件	FLANGE TUBE, WELDMENT	1	1GN100
	1GN125.02.011	轴套管焊合件	FLANGE TUBE, WELDMENT	1	1GN125
	1GN135.02.011	轴套管焊合件	FLANGE TUBE, WELDMENT	1	1GN135
	1GN150.02.011	轴套管焊合件	FLANGE TUBE, WELDMENT	1	1GN150
	1GN180.02.011	轴套管焊合件	FLANGE TUBE, WELDMENT	1	1GN180
	1GN210.02.011	轴套管焊合件	FLANGE TUBE, WELDMENT	1	1GN210
2	1GN100.02.111	II轴	II-SHAFT	1	1GN100
	1GN125.02.111	II轴	II-SHAFT	1	1GN125
	1GN135.02.111	II轴	II-SHAFT	1	1GN135
	1GN150.02.111	II轴	II-SHAFT	1	1GN150
	1GN180.02.111	II轴	II-SHAFT	1	1GN180
	1GN210.02.111	II轴	II-SHAFT	1	1GN210
3	GB13871.1-	唇形密封圈FB42X75X12	SEAL FB42X75X12	1	
4	GB297-30311	圆锥滚子轴承30311	BEARING 30311	1	
5	1GN135.02.108	大锥齿轮	BEVEL GEAR	1	
6	GB13871.1-	密封圈FB型40X70X12	SEAL FB40X70X12	1	
7	GB297-30308	滚子轴承30308	BEARING 30308	1	
8	GB858-30	止动垫圈30	LOCK WASHER 30	1	
9	GB812-M30×1.5	圆螺母M30×1.5	ROUND NUT M30×1.5	1	
10	1GN135.02.107	右端密封垫	GASKET	1	
11	1GN135.02.109	密封垫	GASKET	1	
12	1GN135.02.136	垫圈90	GASKET 90	1	



**FHM**  
FARMER-HELPER  
MACHINERY COMPANY

## Parts Request Form

E-mail [cservice@betstco.com](mailto:cservice@betstco.com)

Phone: 541-895-3083

Name: \_\_\_\_\_

Address: \_\_\_\_\_

City State Zip: \_\_\_\_\_

Phone: \_\_\_\_\_

E-mail: \_\_\_\_\_

Model Number: _____
Serial Number: _____
Purchase From: _____
Purchase Date: _____

Item No.	Description	Qty	Price	Amount

Comments:

## Farmer Helper Machinery Brand LIMITED WARRANTY

FARMER HELPER MACHINERY CO. LTD. warrants to original Purchaser that FARMER HELPER MACHINERY CO. LTD. products are free from major defects in material under normal use and service for a period of Two (2) Years from the date the product is purchased or shipped, whichever is later. Commercial use 180 days. Use at address that is not yours, is considered commercial use. Consumable, Expendable, Wear Items (Examples: Rubber & plastic parts, hydraulic hoses, belts, tires, cables, blades, tines, wedges, teeth, tips, chains, pins, brushes, filters, etc.) and cracked hydraulic pumps, bent or broken cylinder rods are not covered under this warranty. Warranty does not cover items that have been modified, damaged by abuse or usage not in accordance with design or maintenance.

FARMER HELPER MACHINERY CO. LTD.'s obligation under this warranty is to repair or replace defective product upon determination by; Betstco, 83371 Melton Rd. N., Creswell OR 97426 that Warranty Claim is Valid. Product shall be returned upon request of Betstco.

Transportation charges to be prepaid by buyer. **Gasoline or diesel engines used to powered**

**FARMER HELPER MACHINERY CO. LTD. products are covered by the warranty of the appropriate engine manufacture and Purchaser must look to the engine manufacture for all issues relating to engine operation.**

***Farmer-Helper Machinery nor Betstco assumes any responsibility for labor.***

PERMISSIBLE BY APPLICABLE LAW, FARMER HELPER MACHINERY CO. LTD. HEREBY DISCLAIMS ALL WARRANTIES OF ANY KIND, EITHER EXPRESS OR IMPLIED, INCLUDING, ANY IMPLIED WARRANTIES WITH RESPECT TO THE PRODUCT PURCHASED, WITHOUT LIMITING THE GENERALITY OF THE FOREGOING, FARMER HELPER MACHINERY CO. LTD. HEREBY EXPRESSLY DISCLAIMS ALL LIABILITY FOR PRODUCT DEFECT OR FAILURE, CLAIMS THAT ARE DUE TO NORMAL WEAR, PRODUCT MISUSE, ABUSE, PRODUCT MODIFICATION, IMPROPER PRODUCT SELECTION, NON-COMPLIANCE WITH ANY CODES, OR MISAPPROPRIATION. FARMER HELPER MACHINERY CO. LTD. MAKES NO WARRANTIES TO THOSE DEFINED AS "CONSUMERS" IN THE MAGNUSON-MOSS WARRANTY-FEDERAL TRADE COMMISSION IMPROVEMENTS ACT. THE FOREGOING EXCLUSIONS OF IMPLIED WARRANTIES DO NOT APPLY TO THE EXTENT PROHIBITED BY LAW. PLEASE REFER TO YOUR LOCAL LAWS FOR ANY SUCH PROHIBITIONS

THERE SHALL BE NO LIABILITY FOR PRODUCT LIABILITY OR LIABILITY ON THE PART OF BETSTCO FOR ANY GENERAL, SPECIAL OR CONSEQUENTIAL DAMAGES ARISING OUT OF THE SALE OR USE OF ANY PRODUCTS SOLD BY BETSTCO OR AN AGENT THEREOF. BETSTCO MAKES NO WARRANTIES, EXPRESS OR IMPLIED, (INCLUDING, BUT NOT LIMITED TO, ANY WARRANTY OF MERCHANTABILITY OR FITNESS OF THE PRODUCTS FOR ANY PURPOSE) WITH RESPECT TO THE PRODUCTS COVERED BY THIS AGREEMENT EXCEPT AS IN THIS PARAGRAPH OTHERWISE EXPRESSLY PROVIDED.

THIS IS THE SOLE AND ONLY WARRANTY OF FARMER HELPER MACHINERY CO. LTD. PRODUCTS. NO OTHER WARRANTY IS APPLICABLE, EITHER EXPRESSED OR IMPLIED, IN FACT OR BY LAW,

This warranty shall not be interpreted to render Betstco, or any authorized agent liable for injury or damages of any kind or nature, direct, consequential, or contingent, to person or property.

The sole and only remedy in regard to any defective products shall be the repair or replacement thereof as herein provided. Betstco, agent(s) of Betstco shall not be liable for any consequential, special, incidental or punitive damages resulting from or caused by any such defects.

Farmer-Helper Machinery reserves the right to make improvements in design or changes in specifications at any time, without incurring any obligations to owners of units previously sold.

No one is authorized to alter, modify, or enlarge this warranty nor the exclusions, limitations, and reservation thereof.



**WARRANTY VOID IF REGISTRATION IS NOT RECEIVED OR RECORDED ONLINE WITHIN 30 DAYS OF PURCHASE DATE OR SHIP DATE, WHICHEVER IS LATER.**

## REGISTRATION

Item \_\_\_\_\_ Model # \_\_\_\_\_ Purchase Date \_\_\_\_ / \_\_\_\_ / \_\_\_\_  
Purchased From: \_\_\_\_\_ Gift  Inv#/Order# \_\_\_\_\_  
Owner Name: \_\_\_\_\_ Serial # (if Applicable) \_\_\_\_\_  
Owner Address: \_\_\_\_\_  
City: \_\_\_\_\_ County: \_\_\_\_\_ ST: \_\_\_\_\_ Zip Code: \_\_\_\_\_  
Phone: \_\_\_\_\_ Email: \_\_\_\_\_

### Acceptance of responsibility:

I (Purchaser) have read operators manual and Limited Warranty or someone has read/and explained all instructions to me. I understand this warranty does not cover any labor and that all disputes will be settled by binding arbitration. Binding arbitration is conducted by the Better Business Bureau (BBB) located at 4004 SW Kruse Way Place Ste 375 Lake Oswego OR 97035 or the current BBB location closest to Betstco, I acknowledge my Limited Warranty is void if any attempt to repair or replace defective parts has been made by unauthorized personnel. I acknowledge receipt of my Operators Manual and have read the Safe Operation Section. I acknowledge understanding maintenance and safe operation requirements, item specifications, operation, controls, and storage requirements. **I understand that I alone am responsible for proper maintenance, care and safe operation of this Farmer-Helper item.**

I (Purchaser) agree that persons not familiar with the operation of this item should not be allowed to use it. Children especially should not operate or be near Power Products when in use. ANYONE OPERATING VALUE-LEADER PRODUCTS SHOULD HAVE READ OPERATIONS MANUALS AND SAFETY MANUALS.

Owners Signature: x \_\_\_\_\_ Date: \_\_\_\_ / \_\_\_\_ / \_\_\_\_

**You must sign this warranty and mail or fax copy to Betstco, 83371 Melton Rd, Creswell OR 97426. If you prefer you may complete your registration on line. This warranty is not effective unless the Purchaser completes Registration and Warranty Form within 30 days of purchase or ship date whichever is later.**

**Email: [cservice@betstco.com](mailto:cservice@betstco.com)**

NOTE: We may refuse warranty of any kind unless Betstco, receives a completed, legible and signed warranty registration. It is the responsibility of the purchaser to assure that registration document is received by Betstco.

Email: [cservice@betstco.com](mailto:cservice@betstco.com)



## 2 YEAR EXTENDED WARRANTY & REGISTRATION

### Farmer Helper Machinery Branded Products

#### 2 YEAR EXTENDED WARRANTY

2 Year Extended Warranty amends to original Recorded Warranty Registration the time period of described coverage. Extended Warranty does not apply to Consumable and Expendable Items as described in Product Warranty Registration.

This Amendment does not affect any other part of recorded Warranty Registration or Policy.

No one is authorized to alter, modify, or enlarge this Amendment to original recorded warranty registration.

#### EXTENDED REGISTRATION & PAYMENT MUST BE RECEIVED WITHIN 30 DAYS OF PURCHASE DATE

#### EXTENDED WARRANTY REGISTRATION

Product & Model # : \_\_\_\_\_  
Serial #: \_\_\_\_\_  
Owner Name: \_\_\_\_\_  
Betstco Invoice # \_\_\_\_\_

**Acceptance of responsibility:**

I (Purchaser) have Read and understand the Extended Warranty or someone has read/and explained all the above to me. I understand this extended warranty does not cover any labor. I have filed my Original Warranty Registration and fully understand my requirements. **I understand that I alone am responsible for proper maintenance, care and safe operation of this tractor implement.**

I (purchaser) also understand that persons not familiar with the operation of this equipment should not be allowed to use it. Children especially should not operate or be near equipment. ANYONE OPERATING EQUIPMENT SHOULD HAVE READ ALL EQUIPMENT OPERATIONS MANUALS AND SAFETY MANUALS.

**Owner(s Signature:** x \_\_\_\_\_

Date: \_\_\_\_\_

**You must sign this extended warranty and email to [cservice@betstco.com](mailto:cservice@betstco.com) or mail copy to Betstco, 83371 Melton Rd, Creswell OR 97426. This extended warranty is not effective unless the Purchaser faxes or mails this Registration Form within 30 days of purchase. NOTE:** The manufacturer may refuse warranty of any kind unless Betstco receives a completed, legible and signed extended warranty registration. It is the responsibility of the purchaser to assure that this registration document is received by Betstco.

**To Make Payment for Extended Warranty Call: 541-895-3083**